

## 4-20mA CURRENT LOOP TRANSMITTERS

### FEATURES

- LOW QUIESCENT CURRENT: 200µA
- 5V REGULATOR FOR EXTERNAL CIRCUITS
- $V_{REF}$  FOR SENSOR EXCITATION:  
XTR115: 2.5V  
XTR116: 4.096V
- LOW SPAN ERROR: 0.05%
- LOW NONLINEARITY ERROR: 0.003%
- WIDE LOOP SUPPLY RANGE: 7.5V to 36V
- SO-8 PACKAGE

### DESCRIPTION

The XTR115 and XTR116 are precision current output converters designed to transmit analog 4-to-20mA signals over an industry standard current loop. They provide accurate current scaling and output current limit functions.

The on-chip voltage regulator (5V) can be used to power external circuitry. A precision on-chip  $V_{REF}$  (2.5V for XTR115 and 4.096V for XTR116) can be

### APPLICATIONS

- 2-WIRE, 4-20mA CURRENT LOOP TRANSMITTER
- SMART TRANSMITTER
- INDUSTRIAL PROCESS CONTROL
- TEST SYSTEMS
- COMPATIBLE WITH HART MODEM
- CURRENT AMPLIFIER
- VOLTAGE-TO-CURRENT AMPLIFIER

used for offsetting or to excite transducers. A current return pin ( $I_{RET}$ ) senses any current used in external circuitry to assure an accurate control of the output current.

The XTR115 is a fundamental building block of smart sensors using 4-to-20mA current transmission.

The XTR115 and XTR116 are specified for operation over the extended industrial temperature range,  $-40^{\circ}\text{C}$  to  $+85^{\circ}\text{C}$ .

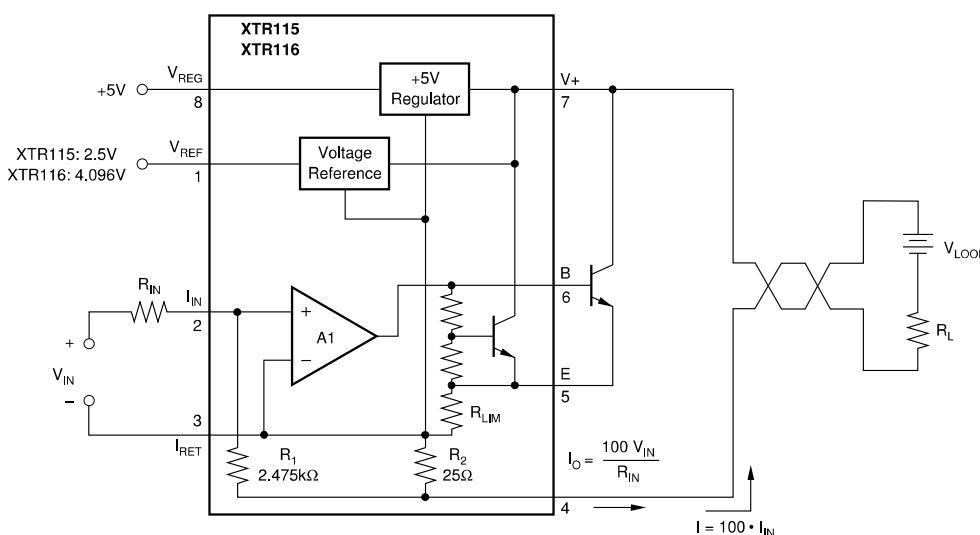

Please be aware that an important notice concerning availability, standard warranty, and use in critical applications of Texas Instruments semiconductor products and disclaimers thereto appears at the end of this data sheet.

All trademarks are the property of their respective owners.

PRODUCTION DATA information is current as of publication date. Products conform to specifications per the terms of Texas Instruments standard warranty. Production processing does not necessarily include testing of all parameters.

# SPECIFICATIONS

At  $T_A = +25^\circ\text{C}$ ,  $V_+ = 24\text{V}$ ,  $R_{IN} = 20\text{k}\Omega$ , and TIP29C external transistor, unless otherwise noted.

PARAMETER	CONDITIONS	XTR115U XTR116U			XTR115UA XTR116UA			UNITS
		MIN	TYP	MAX	MIN	TYP	MAX	
<b>OUTPUT</b>								
Output Current Equation	$I_O$		$I_O = I_{IN} \cdot 100$		*	*	*	mA
Output Current, Linear Range		0.25		25	*	*	*	mA
Over-Scale Limit	$I_{LIM}$		32		*	*	*	mA
Under-Scale Limit	$I_{MIN}$		0.2	0.25	*	*	*	mA
<b>SPAN</b>								
Span (Current Gain)	S		100			*		A/A
Error <sup>(1)</sup>			$\pm 0.05$	$\pm 0.2$		*	$\pm 0.4$	%
vs Temperature	$I_{IN} = 250\mu\text{A}$ to $25\text{mA}$ $T_A = -40^\circ\text{C}$ to $+85^\circ\text{C}$		$\pm 3$	$\pm 20$		*	*	ppm/ $^\circ\text{C}$
Nonlinearity	$I_{IN} = 250\mu\text{A}$ to $25\text{mA}$		$\pm 0.003$	$\pm 0.01$		*	$\pm 0.02$	%
<b>INPUT</b>								
Offset Voltage (Op Amp)	$V_{OS}$		$\pm 100$	$\pm 250$		*	$\pm 500$	$\mu\text{V}$
vs Temperature	$I_{IN} = 40\mu\text{A}$ $T_A = -40^\circ\text{C}$ to $+85^\circ\text{C}$		$\pm 0.7$	$\pm 3$		*	$\pm 6$	$\mu\text{V}/^\circ\text{C}$
vs Supply Voltage, V+	$V_+ = 7.5\text{V}$ to $36\text{V}$		$\pm 0.1$	$\pm 2$		*	*	$\mu\text{V}/\text{V}$
Bias Current	$I_B$		$-35$			*		nA
vs Temperature			150			*		pA/ $^\circ\text{C}$
Noise: 0.1Hz to 10Hz	$e_n$		0.6			*		$\mu\text{Vp-p}$
<b>DYNAMIC RESPONSE</b>								
Small Signal Bandwidth	$C_{LOOP} = 0$ , $R_L = 0$		380			*		kHz
Slew Rate			3.2			*		mA/ $\mu\text{s}$
<b><math>V_{REF}^{(2)}</math></b>								
XTR115			2.5			*		V
XTR116			4.096			*		V
Voltage Accuracy	$I_{REF} = 0$		$\pm 0.05$	$\pm 0.25$		*	$\pm 0.5$	%
vs Temperature	$T_A = -40^\circ\text{C}$ to $+85^\circ\text{C}$		$\pm 20$	$\pm 35$		*	$\pm 75$	ppm/ $^\circ\text{C}$
vs Supply Voltage, V+	$V_+ = 7.5\text{V}$ to $36\text{V}$		$\pm 1$	$\pm 10$		*	*	ppm/V
vs Load	$I_{REF} = 0\text{mA}$ to $2.5\text{mA}$		$\pm 100$			*	*	ppm/mA
Noise: 0.1Hz to 10Hz			10			*		$\mu\text{Vp-p}$
Short-Circuit Current			16			*		mA
<b><math>V_{REG}^{(2)}</math></b>								
Voltage	$I_{REG} = 0$		5	$\pm 0.1$		*	*	V
Voltage Accuracy	$T_A = -40^\circ\text{C}$ to $+85^\circ\text{C}$		$\pm 0.05$	$\pm 0.1$		*	*	V
vs Temperature	$V_+ = 7.5\text{V}$ to $36\text{V}$		1			*	*	mV/ $^\circ\text{C}$
vs Supply Voltage, V+			See Typical Curves			*	*	mV/V
vs Output Current			12			*	*	mA
Short-Circuit Current						*	*	mA
<b>POWER SUPPLY</b>	$V_+$							
Specified			+7.5	+24		*	*	V
Voltage Range				+36		*	*	V
Quiescent Current				200		*	*	$\mu\text{A}$
Over Temperature, $-40^\circ\text{C}$ to $+85^\circ\text{C}$				240		*	*	$\mu\text{A}$
<b>TEMPERATURE RANGE</b>								
Specification			$-40$	$+85$		*	*	$^\circ\text{C}$
Operating			$-55$	$+125$		*	*	$^\circ\text{C}$
Storage			$-55$	$+125$		*	*	$^\circ\text{C}$
Thermal Resistance	$\theta_{JA}$		150			*	*	$^\circ\text{C}/\text{W}$

\* Specifications the same as XTR115U and XTR116U.

NOTES: (1) Does not include initial error or TCR of  $R_{IN}$ . (2) Voltage measured with respect to  $I_{REF}$  pin.

## PIN CONFIGURATION

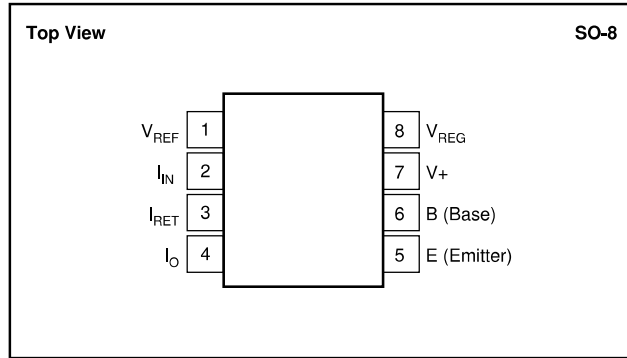

## PACKAGE/ORDERING INFORMATION

For the most current package and ordering information, see the Package Option Addendum located at the end of this data sheet.

## ABSOLUTE MAXIMUM RATINGS<sup>(1)</sup>

Power Supply, V+ (referenced to I <sub>O</sub> pin)	40V
Input Voltage (referenced to I <sub>RET</sub> pin)	0V to V+
Output Current Limit	Continuous
V <sub>REG</sub> , Short-Circuit	Continuous
V <sub>REF</sub> , Short-Circuit	Continuous
Operating Temperature	-55°C to +125°C
Storage Temperature Range	-55°C to +125°C
Lead Temperature (soldering, 10s)	+300°C
Junction Temperature	+165°C

NOTE: (1) Stresses above these ratings may cause permanent damage. Exposure to absolute maximum conditions for extended periods may degrade device reliability.



## ELECTROSTATIC DISCHARGE SENSITIVITY

This integrated circuit can be damaged by ESD. Texas Instruments recommends that all integrated circuits be handled with appropriate precautions. Failure to observe proper handling and installation procedures can cause damage.

ESD damage can range from subtle performance degradation to complete device failure. Precision integrated circuits may be more susceptible to damage because very small parametric changes could cause the device not to meet its published specifications.

# TYPICAL PERFORMANCE CURVES

At  $T_A = +25^\circ\text{C}$ ,  $V_+ = 24\text{V}$ ,  $R_{IN} = 20\text{k}\Omega$ , and TIP29C external transistor, unless otherwise noted.

CURRENT GAIN vs FREQUENCY

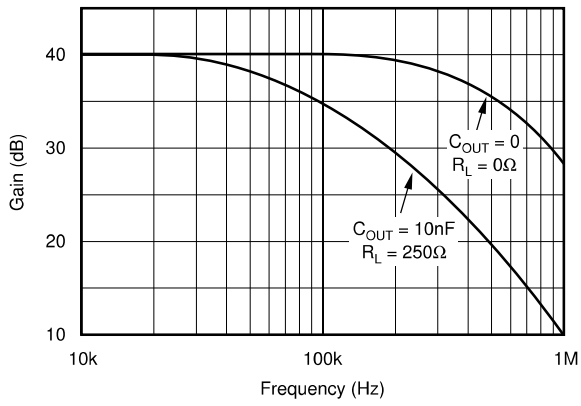

QUIESCENT CURRENT vs TEMPERATURE

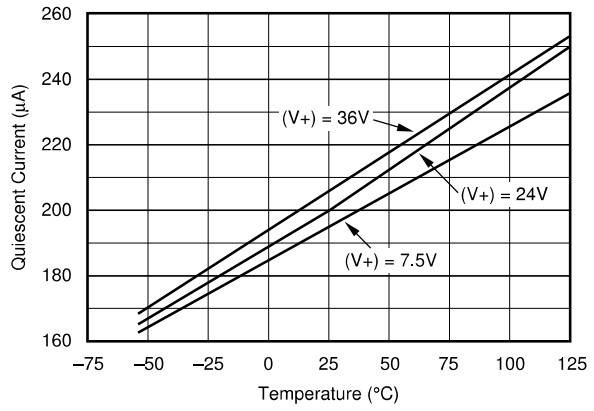

REFERENCE VOLTAGE vs TEMPERATURE

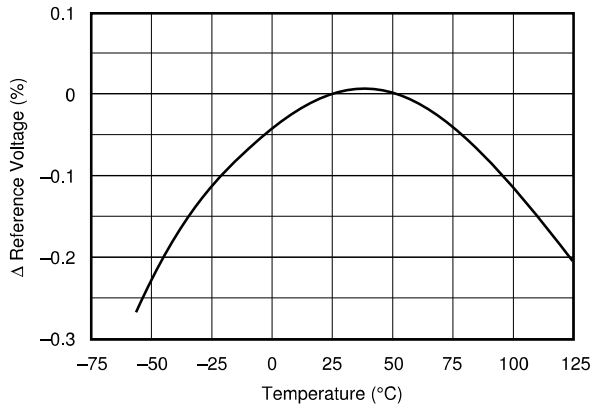

OVER-SCALE CURRENT vs TEMPERATURE

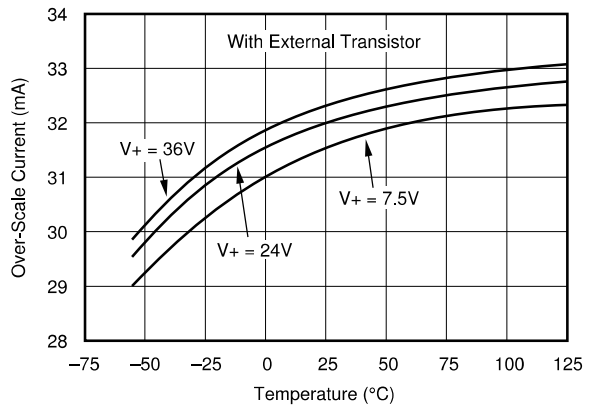

$V_{REG}$  VOLTAGE vs  $V_{REG}$  CURRENT

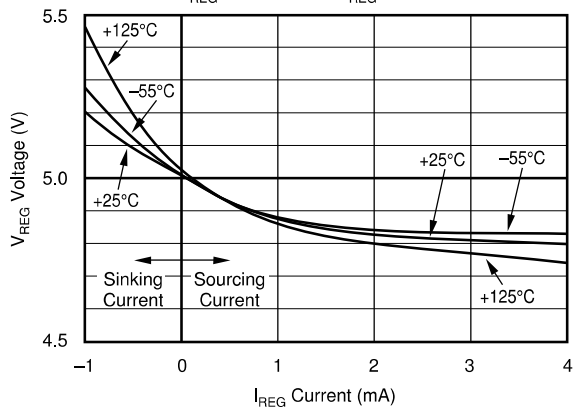

# APPLICATIONS INFORMATION

The XTR115 and XTR116 are identical devices except for the reference voltage output, pin 1. This voltage is available for external circuitry and is not used internally. Further discussions that apply to both devices will refer to the “XTR115/6.”

Figure 1 shows basic circuit connections with representative simplified input circuitry. The XTR115/6 is a two-wire current transmitter. Its input signal (pin 2) controls the output current. A portion of this current flows into the V+ power supply, pin 7. The remaining current flows in Q1. External input circuitry connected to the XTR115/6 can be powered from V<sub>REG</sub> or V<sub>REF</sub>. Current drawn from these terminals must be returned to I<sub>RET</sub>, pin 3. This I<sub>RET</sub> pin is a “local ground” for input circuitry driving the XTR115/6.

The XTR115/6 is a current-input device with a gain of 100. A current flowing into pin 2 produces I<sub>O</sub> = 100 • I<sub>IN</sub>. The input voltage at the I<sub>IN</sub> pin is zero (referred to the I<sub>RET</sub> pin). A voltage input is created with an external input resistor, as shown. Common full-scale input voltages range from 1V

and upward. Full-scale inputs greater than 0.5V are recommended to minimize the effect of offset voltage and drift of A1.

## EXTERNAL TRANSISTOR

The external transistor, Q1, conducts the majority of the full-scale output current. Power dissipation in this transistor can approach 0.8W with high loop voltage (40V) and 20mA output current. The XTR115/6 is designed to use an external transistor to avoid on-chip thermal-induced errors. Heat produced by Q1 will still cause ambient temperature changes that can affect the XTR115/6. To minimize these effects, locate Q1 away from sensitive analog circuitry, including XTR115/6. Mount Q1 so that heat is conducted to the outside of the transducer housing.

The XTR115/6 is designed to use virtually any NPN transistor with sufficient voltage, current and power rating. Case style and thermal mounting considerations often influence the choice for any given application. Several possible choices are listed in Figure 1. A MOSFET transistor will not improve the accuracy of the XTR115/6 and is not recommended.

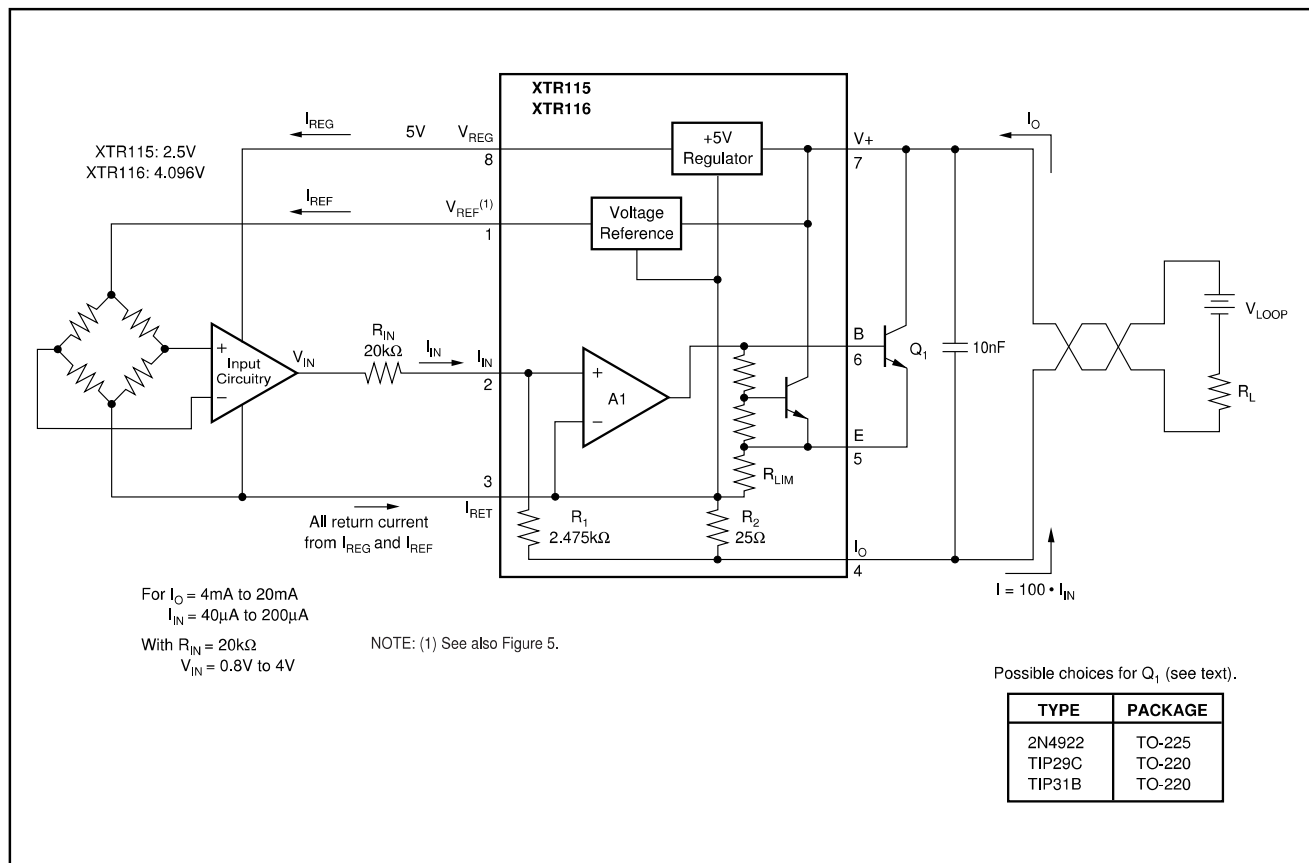

FIGURE 1. Basic Circuit Connections.

## MINIMUM-SCALE CURRENT

The quiescent current of the XTR115/6 (typically 200 $\mu$ A) is the lower limit of its output current. Zero input current ( $I_{IN} = 0$ ) will produce an  $I_O$  equal to the quiescent current. Output current will not begin to increase until  $I_{IN} > I_Q/100$ . Current drawn from  $V_{REF}$  or  $V_{REG}$  will add to this minimum output current. This means that more than 3.7mA is available to power external circuitry while still allowing the output current to go below 4mA.

## OFFSETTING THE INPUT

A low scale of 4mA is produced by creating a 40 $\mu$ A input current. This can be created with the proper value resistor from  $V_{REF}$  (Figure 2), or by generating offset in the input drive circuitry.

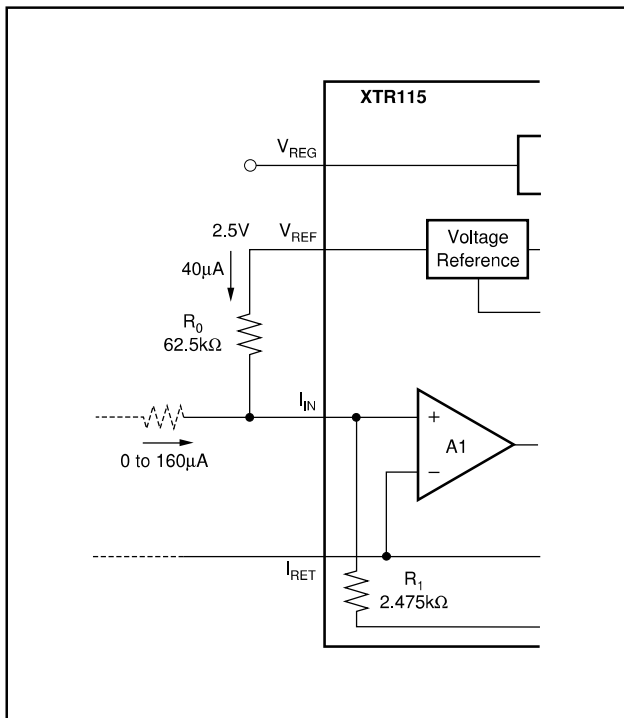

FIGURE 2. Creating Low-Scale Offset.

## MAXIMUM OUTPUT CURRENT

The XTR115/6 provides accurate, linear output up to 25mA. Internal circuitry limits the output current to approximately 32mA to protect the transmitter and loop power/measurement circuitry.

It is possible to extend the output current range of the XTR115/6 by connecting an external resistor from pin 3 to pin 5, to change the current limit value. Since all output current must flow through internal resistors, it is possible to damage with excessive current. Output currents greater than 45mA may cause permanent damage.

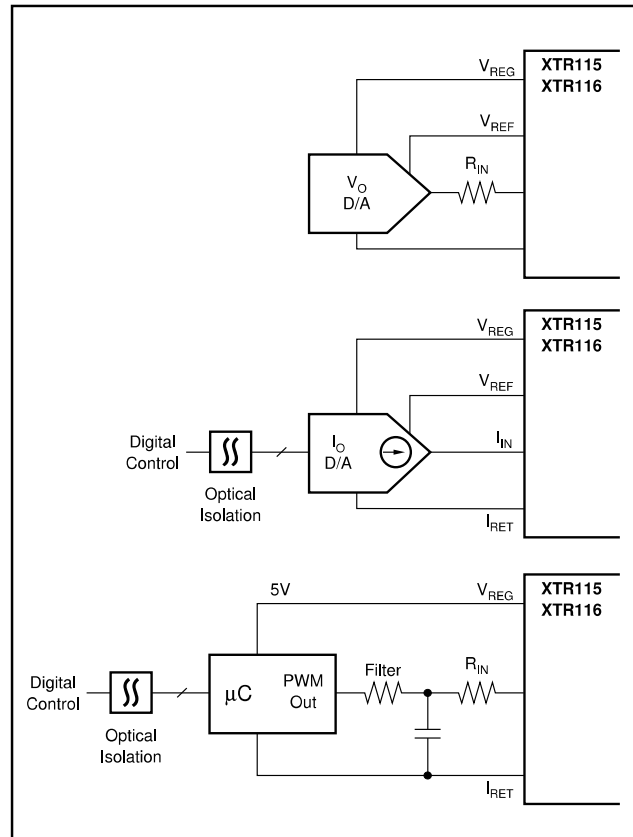

FIGURE 3. Digital Control Methods.

## REVERSE-VOLTAGE PROTECTION

The XTR115/6 low compliance voltage rating (7.5V) permits the use of various voltage protection methods without compromising operating range. Figure 4 shows a diode bridge circuit which allows normal operation even when the voltage connection lines are reversed. The bridge causes a two diode drop (approximately 1.4V) loss in loop supply voltage. This results in a compliance voltage of approximately 9V—satisfactory for most applications. A diode can be inserted in series with the loop supply voltage and the V+ pin to protect against reverse output connection lines with only a 0.7V loss in loop supply voltage.

## OVER-VOLTAGE SURGE PROTECTION

Remote connections to current transmitters can sometimes be subjected to voltage surges. It is prudent to limit the maximum surge voltage applied to the XTR115/6 to as low as practical. Various zener diode and surge clamping diodes are specially designed for this purpose. Select a clamp diode with as low a voltage rating as possible for best protection. For example, a 36V protection diode will assure proper transmitter operation at normal loop voltages, yet will provide an appropriate level of protection against voltage surges. Characterization tests on several production lots showed no damage with loop supply voltages up to 65V.

Most surge protection zener diodes have a diode characteristic in the forward direction that will conduct excessive current, possibly damaging receiving-side circuitry if the loop connections are reversed. If a surge protection diode is used, a series diode or diode bridge should be used for protection against reversed connections.

## RADIO FREQUENCY INTERFERENCE

The long wire lengths of current loops invite radio frequency interference. RF can be rectified by the input circuitry of the XTR115/6 or preceding circuitry. This generally appears as an unstable output current that varies with the position of loop supply or input wiring.

Interference may also enter at the input terminals. For integrated transmitter assemblies with short connection to the sensor, the interference more likely comes from the current loop connections.

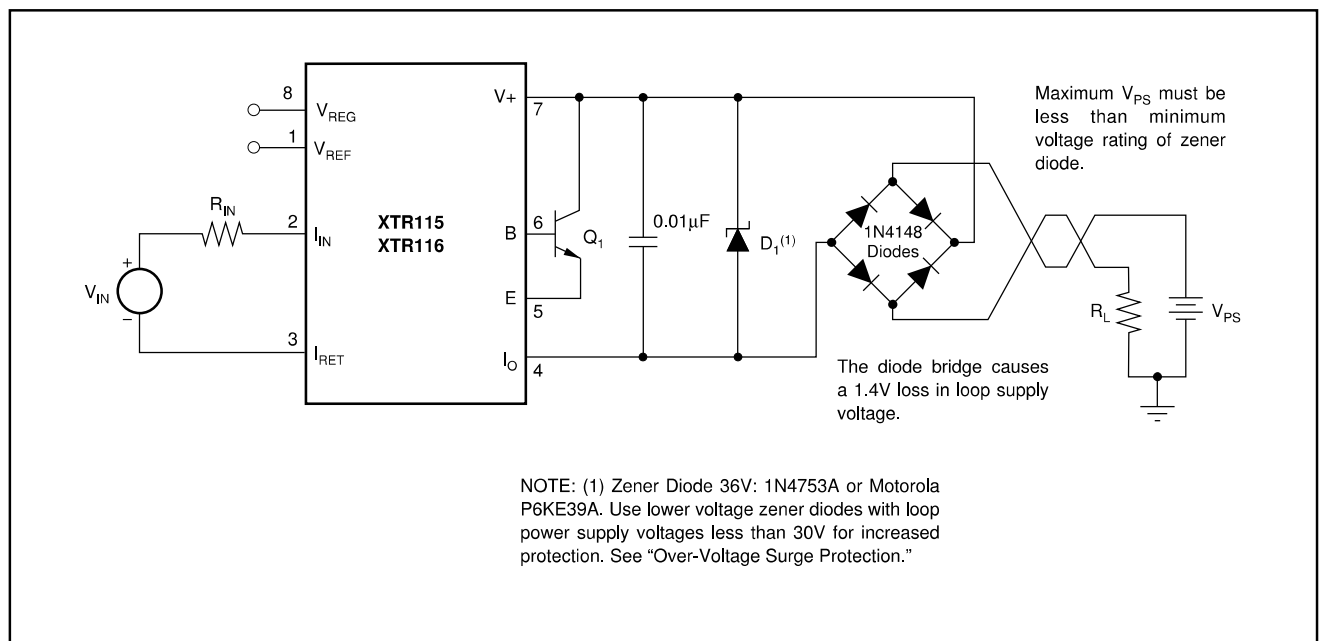
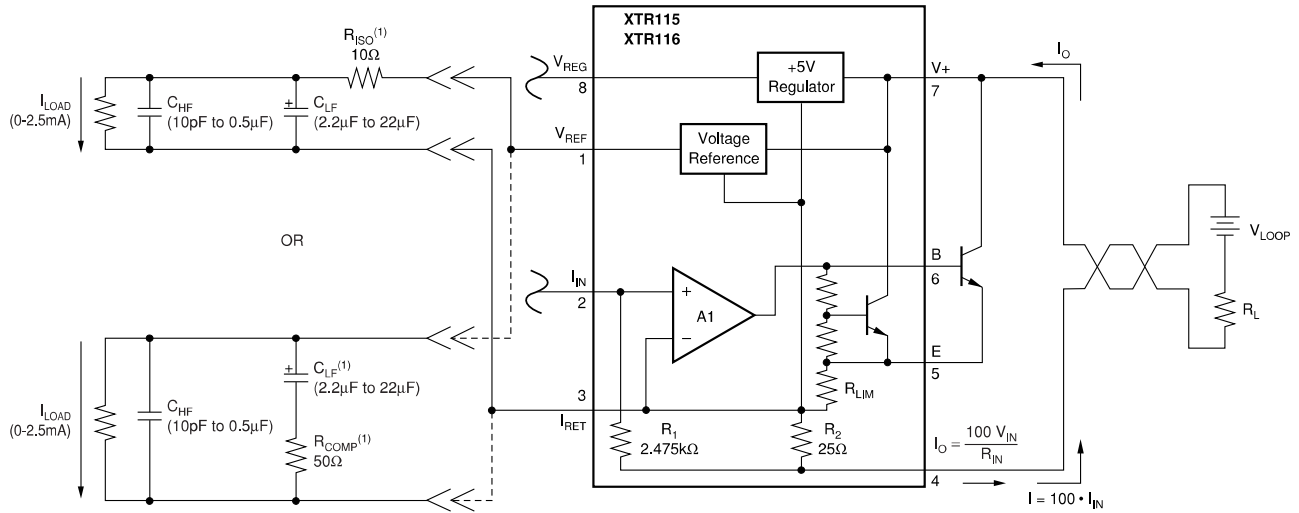

FIGURE 4. Reverse Voltage Operation and Over-Voltage Surge Protection.

If capacitive loading must be placed on the  $V_{REF}$  pin, one of the compensation schemes shown below must be used to ensure stable operation. Values of capacitance must remain within the given ranges.



NOTE: (1) Required compensation components.

FIGURE 5. Stable Operation with Capacitive Load on  $V_{REF}$ .



**PACKAGING INFORMATION**

Orderable Device	Status (1)	Package Type	Package Drawing	Pins	Package Qty	Eco Plan (2)	Lead/Ball Finish (6)	MSL Peak Temp (3)	Op Temp (°C)	Device Marking (4/5)	Samples
XTR115U	ACTIVE	SOIC	D	8	75	Green (RoHS & no Sb/Br)	CU NIPDAU	Level-3-260C-168 HR		XTR 115U	Samples
XTR115UJ/2K5	ACTIVE	SOIC	D	8	2500	Green (RoHS & no Sb/Br)	CU NIPDAU	Level-3-260C-168 HR		XTR 115U	Samples
XTR115UJ/2K5E4	ACTIVE	SOIC	D	8	2500	Green (RoHS & no Sb/Br)	CU NIPDAU	Level-3-260C-168 HR		XTR 115U	Samples
XTR115UA	ACTIVE	SOIC	D	8	75	Green (RoHS & no Sb/Br)	CU NIPDAU	Level-3-260C-168 HR		XTR 115U A	Samples
XTR115UA/2K5	ACTIVE	SOIC	D	8	2500	Green (RoHS & no Sb/Br)	CU NIPDAU	Level-3-260C-168 HR		XTR 115U A	Samples
XTR115UA/2K5E4	ACTIVE	SOIC	D	8	2500	Green (RoHS & no Sb/Br)	CU NIPDAU	Level-3-260C-168 HR		XTR 115U A	Samples
XTR115UAE4	ACTIVE	SOIC	D	8		TBD	Call TI	Call TI		XTR 115U A	Samples
XTR115UG4	ACTIVE	SOIC	D	8	75	Green (RoHS & no Sb/Br)	CU NIPDAU	Level-3-260C-168 HR		XTR 115U	Samples
XTR116U	ACTIVE	SOIC	D	8	75	Green (RoHS & no Sb/Br)	CU NIPDAU	Level-3-260C-168 HR		XTR 116U	Samples
XTR116U/2K5	ACTIVE	SOIC	D	8	2500	Green (RoHS & no Sb/Br)	CU NIPDAU	Level-3-260C-168 HR		XTR 116U	Samples
XTR116U/2K5G4	ACTIVE	SOIC	D	8	2500	Green (RoHS & no Sb/Br)	CU NIPDAU	Level-3-260C-168 HR		XTR 116U	Samples
XTR116UA	ACTIVE	SOIC	D	8	75	Green (RoHS & no Sb/Br)	CU NIPDAU	Level-3-260C-168 HR		XTR 116U A	Samples
XTR116UA/2K5	ACTIVE	SOIC	D	8	2500	Green (RoHS & no Sb/Br)	CU NIPDAU	Level-3-260C-168 HR		XTR 116U A	Samples
XTR116UA/2K5E4	ACTIVE	SOIC	D	8	2500	Green (RoHS & no Sb/Br)	CU NIPDAU	Level-3-260C-168 HR		XTR 116U A	Samples



www.ti.com

# PACKAGE OPTION ADDENDUM

9-May-2014

Orderable Device	Status <sup>(1)</sup>	Package Type	Package Drawing	Package Pins	Package Qty	Eco Plan <sup>(2)</sup>	Lead/Ball Finish <sup>(6)</sup>	MSL Peak Temp <sup>(3)</sup>	Op Temp (°C)	Device Marking <sup>(4/5)</sup>	Samples
XTR116UAE4	ACTIVE	SOIC	D	8	75	Green (RoHS & no Sb/Br)	CU NIPDAU	Level-3-260C-168 HR		XTR 116U A	Samples
XTR116UG4	ACTIVE	SOIC	D	8	75	Green (RoHS & no Sb/Br)	CU NIPDAU	Level-3-260C-168 HR		XTR 116U	Samples

<sup>(1)</sup> The marketing status values are defined as follows:

**ACTIVE:** Product device recommended for new designs.

**LIFEBUY:** TI has announced that the device will be discontinued, and a lifetime-buy period is in effect.

**NRND:** Not recommended for new designs. Device is in production to support existing customers, but TI does not recommend using this part in a new design.

**PREVIEW:** Device has been announced but is not in production. Samples may or may not be available.

**OBSOLETE:** TI has discontinued the production of the device.

<sup>(2)</sup> Eco Plan - The planned eco-friendly classification: Pb-Free (RoHS), Pb-Free (RoHS), Pb-Free (RoHS Exempt), or Green (RoHS & no Sb/Br) - please check <http://www.ti.com/productcontent> for the latest availability information and additional product content details.

**TBD:** The Pb-Free/Green conversion plan has not been defined.

**Pb-Free (RoHS):** TI's terms "Lead-Free" or "Pb-Free" mean semiconductor products that are compatible with the current RoHS requirements for all 6 substances, including the requirement that lead not exceed 0.1% by weight in homogeneous materials. Where designed to be soldered at high temperatures, TI Pb-Free products are suitable for use in specified lead-free processes.

**Pb-Free (RoHS Exempt):** This component has a RoHS exemption for either 1) lead-based flip-chip solder bumps used between the die and package, or 2) lead-based die adhesive used between the die and leadframe. The component is otherwise considered Pb-Free (RoHS compatible) as defined above.

**Green (RoHS & no Sb/Br):** TI defines "Green" to mean Pb-Free (RoHS compatible), and free of Bromine (Br) and Antimony (Sb) based flame retardants (Br or Sb do not exceed 0.1% by weight in homogeneous material)

<sup>(3)</sup> MSL, Peak Temp. - The Moisture Sensitivity Level rating according to the JEDEC industry standard classifications, and peak solder temperature.

<sup>(4)</sup> There may be additional marking, which relates to the logo, the lot trace code information, or the environmental category on the device.

<sup>(5)</sup> Multiple Device Markings will be inside parentheses. Only one Device Marking contained in parentheses and separated by a "-" will appear on a device. If a line is indented then it is a continuation of the previous line and the two combined represent the entire Device Marking for that device.

<sup>(6)</sup> Lead/Ball Finish - Orderable Devices may have multiple material finish options. Finish options are separated by a vertical ruled line. Lead/Ball Finish values may wrap to two lines if the finish value exceeds the maximum column width.

**Important Information and Disclaimer:** The information provided on this page represents TI's knowledge and belief as of the date that it is provided. TI bases its knowledge and belief on information provided by third parties, and makes no representation or warranty as to the accuracy of such information. Efforts are underway to better integrate information from third parties. TI has taken and continues to take reasonable steps to provide representative and accurate information but may not have conducted destructive testing or chemical analysis on incoming materials and chemicals. TI and TI suppliers consider certain information to be proprietary, and thus CAS numbers and other limited information may not be available for release.



[www.ti.com](http://www.ti.com)

9-May-2014

---

In no event shall TI's liability arising out of such information exceed the total purchase price of the TI part(s) at issue in this document sold by TI to Customer on an annual basis.

**TAPE AND REEL INFORMATION**

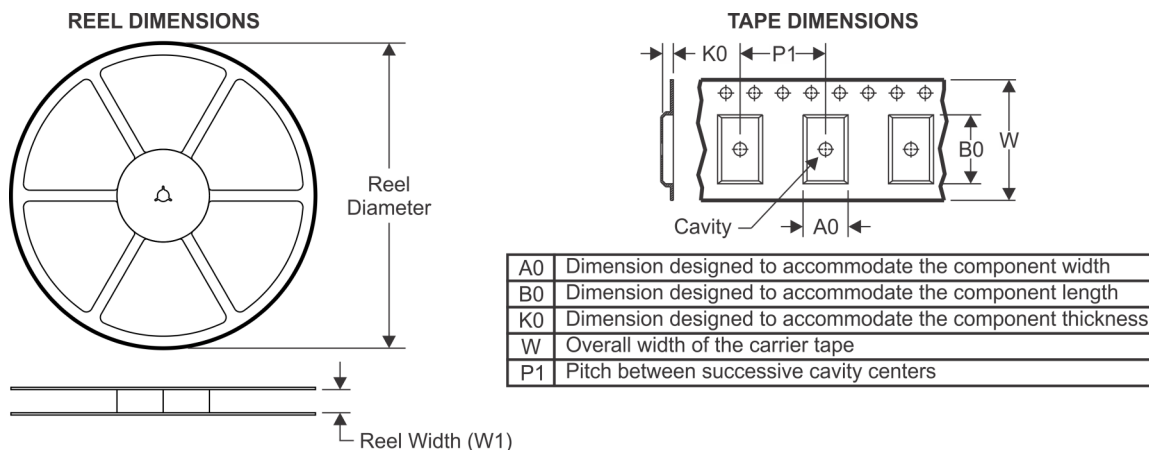

**QUADRANT ASSIGNMENTS FOR PIN 1 ORIENTATION IN TAPE**

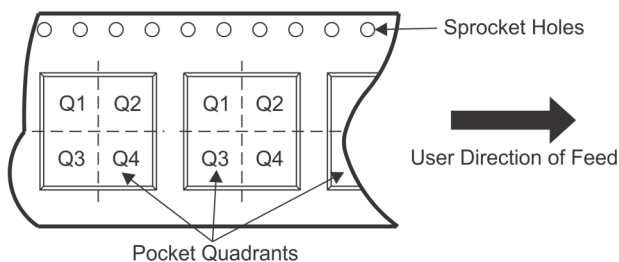

\*All dimensions are nominal

Device	Package Type	Package Drawing	Pins	SPQ	Reel Diameter (mm)	Reel Width W1 (mm)	A0 (mm)	B0 (mm)	K0 (mm)	P1 (mm)	W (mm)	Pin1 Quadrant
XTR115U/2K5	SOIC	D	8	2500	330.0	12.4	6.4	5.2	2.1	8.0	12.0	Q1
XTR115UA/2K5	SOIC	D	8	2500	330.0	12.4	6.4	5.2	2.1	8.0	12.0	Q1
XTR116U/2K5	SOIC	D	8	2500	330.0	12.4	6.4	5.2	2.1	8.0	12.0	Q1

**TAPE AND REEL BOX DIMENSIONS**

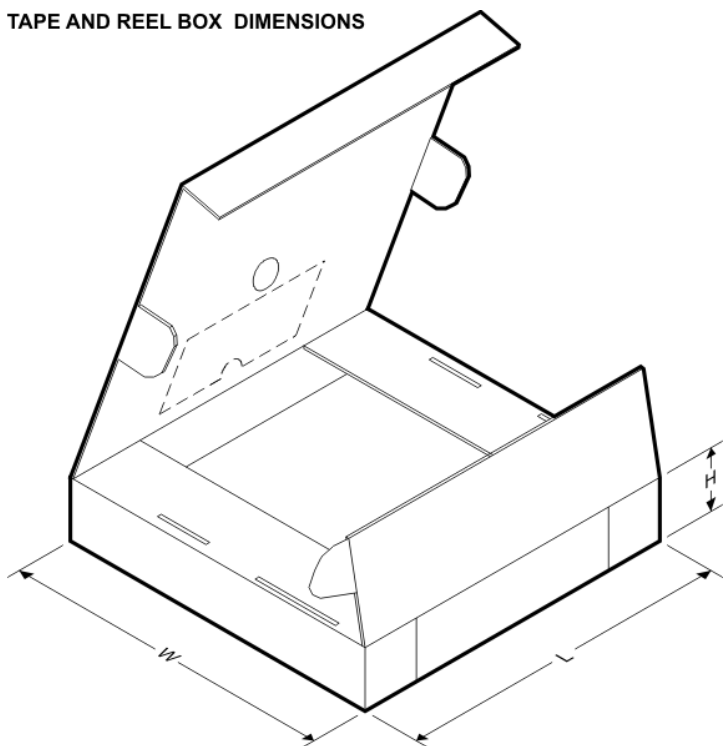

\*All dimensions are nominal

Device	Package Type	Package Drawing	Pins	SPQ	Length (mm)	Width (mm)	Height (mm)
XTR115U/2K5	SOIC	D	8	2500	367.0	367.0	35.0
XTR115UA/2K5	SOIC	D	8	2500	367.0	367.0	35.0
XTR116U/2K5	SOIC	D	8	2500	367.0	367.0	35.0

# MECHANICAL DATA

D (R-PDSO-G8)

PLASTIC SMALL OUTLINE

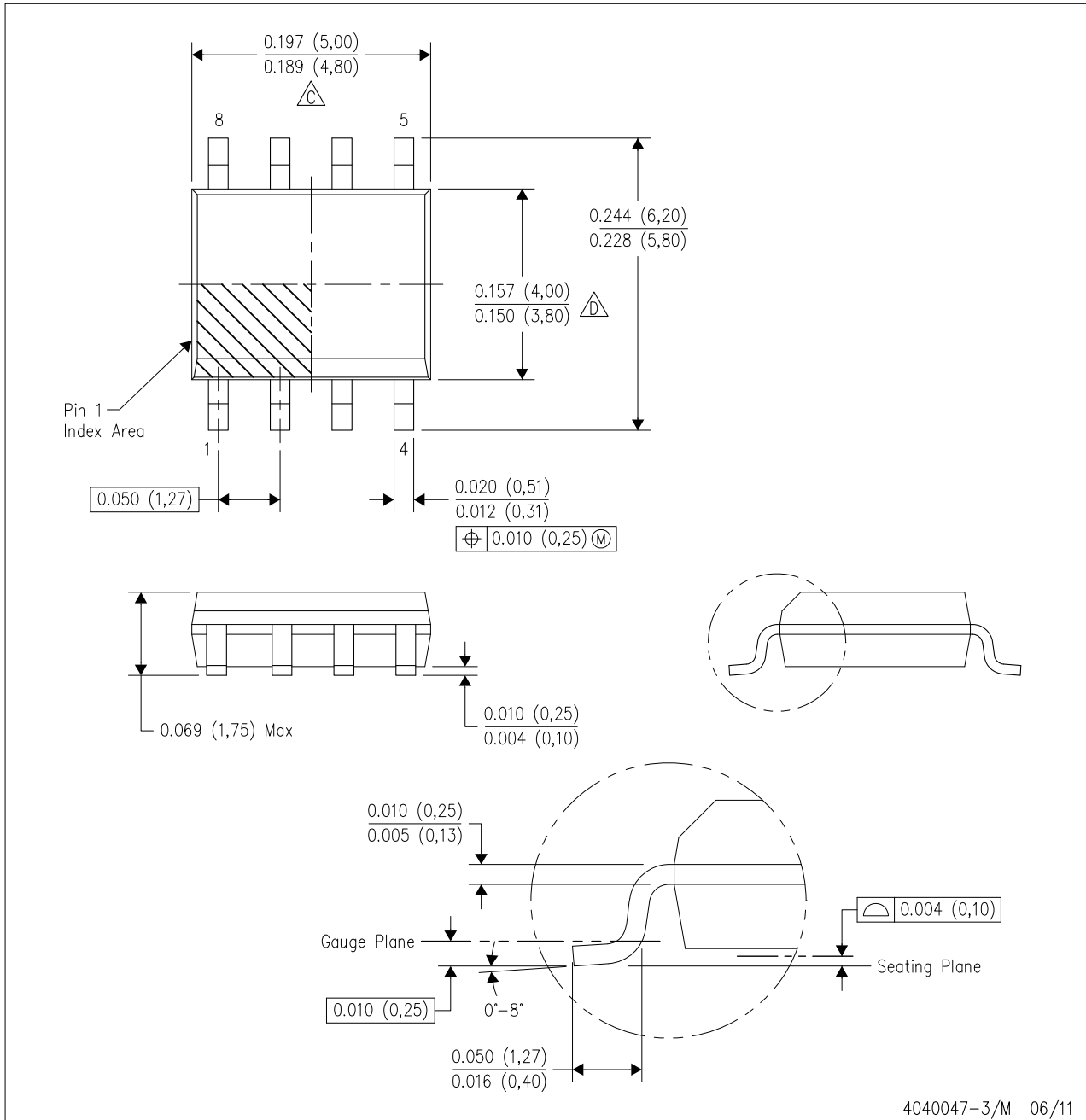

4040047-3/M 06/11

# LAND PATTERN DATA

D (R-PDSO-G8)

PLASTIC SMALL OUTLINE

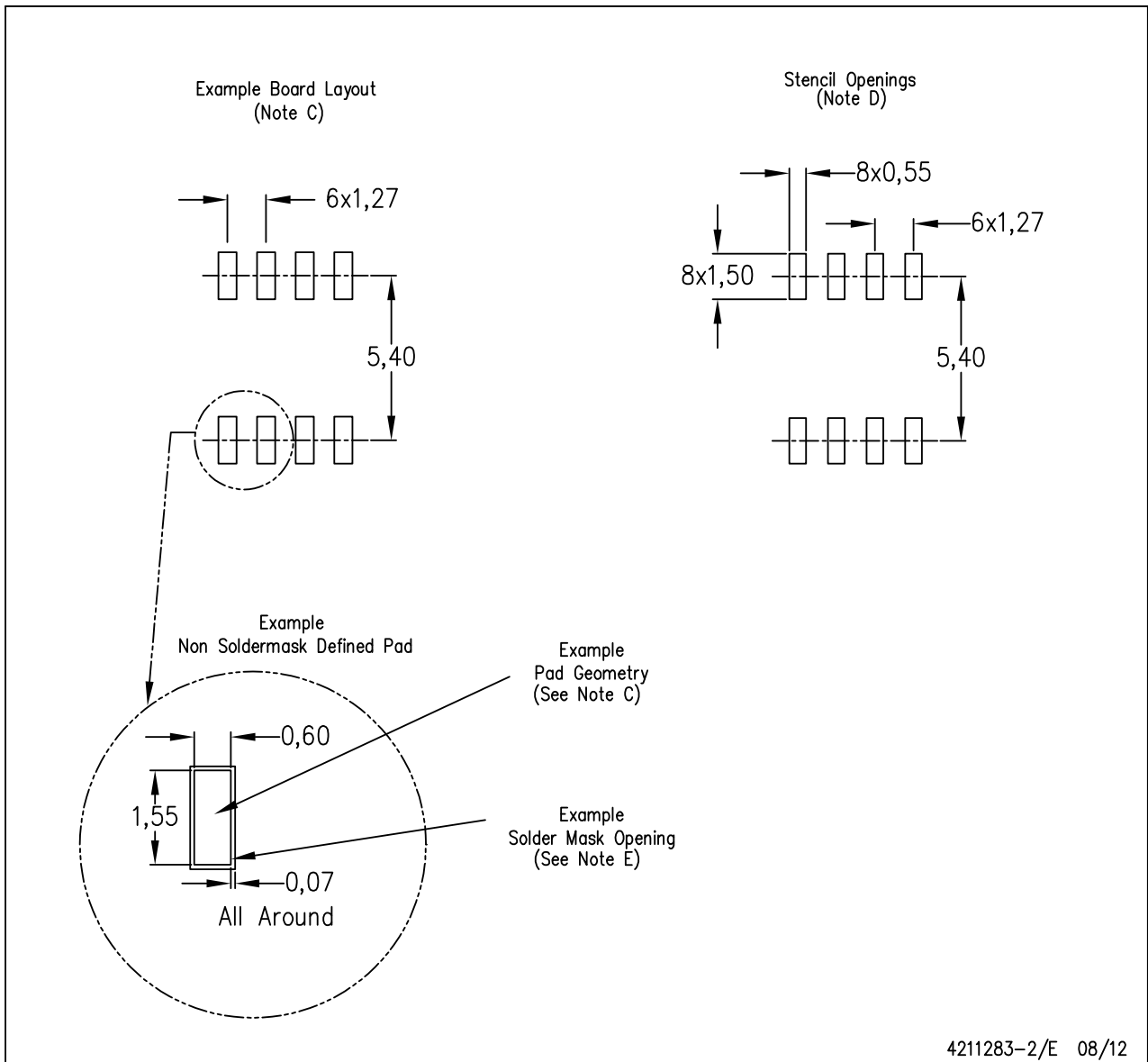

- NOTES:
- All linear dimensions are in millimeters.
  - This drawing is subject to change without notice.
  - Publication IPC-7351 is recommended for alternate designs.
  - Laser cutting apertures with trapezoidal walls and also rounding corners will offer better paste release. Customers should contact their board assembly site for stencil design recommendations. Refer to IPC-7525 for other stencil recommendations.
  - Customers should contact their board fabrication site for solder mask tolerances between and around signal pads.

## IMPORTANT NOTICE

Texas Instruments Incorporated and its subsidiaries (TI) reserve the right to make corrections, enhancements, improvements and other changes to its semiconductor products and services per JESD46, latest issue, and to discontinue any product or service per JESD48, latest issue. Buyers should obtain the latest relevant information before placing orders and should verify that such information is current and complete. All semiconductor products (also referred to herein as “components”) are sold subject to TI’s terms and conditions of sale supplied at the time of order acknowledgment.

TI warrants performance of its components to the specifications applicable at the time of sale, in accordance with the warranty in TI’s terms and conditions of sale of semiconductor products. Testing and other quality control techniques are used to the extent TI deems necessary to support this warranty. Except where mandated by applicable law, testing of all parameters of each component is not necessarily performed.

TI assumes no liability for applications assistance or the design of Buyers’ products. Buyers are responsible for their products and applications using TI components. To minimize the risks associated with Buyers’ products and applications, Buyers should provide adequate design and operating safeguards.

TI does not warrant or represent that any license, either express or implied, is granted under any patent right, copyright, mask work right, or other intellectual property right relating to any combination, machine, or process in which TI components or services are used. Information published by TI regarding third-party products or services does not constitute a license to use such products or services or a warranty or endorsement thereof. Use of such information may require a license from a third party under the patents or other intellectual property of the third party, or a license from TI under the patents or other intellectual property of TI.

Reproduction of significant portions of TI information in TI data books or data sheets is permissible only if reproduction is without alteration and is accompanied by all associated warranties, conditions, limitations, and notices. TI is not responsible or liable for such altered documentation. Information of third parties may be subject to additional restrictions.

Resale of TI components or services with statements different from or beyond the parameters stated by TI for that component or service voids all express and any implied warranties for the associated TI component or service and is an unfair and deceptive business practice. TI is not responsible or liable for any such statements.

Buyer acknowledges and agrees that it is solely responsible for compliance with all legal, regulatory and safety-related requirements concerning its products, and any use of TI components in its applications, notwithstanding any applications-related information or support that may be provided by TI. Buyer represents and agrees that it has all the necessary expertise to create and implement safeguards which anticipate dangerous consequences of failures, monitor failures and their consequences, lessen the likelihood of failures that might cause harm and take appropriate remedial actions. Buyer will fully indemnify TI and its representatives against any damages arising out of the use of any TI components in safety-critical applications.

In some cases, TI components may be promoted specifically to facilitate safety-related applications. With such components, TI’s goal is to help enable customers to design and create their own end-product solutions that meet applicable functional safety standards and requirements. Nonetheless, such components are subject to these terms.

No TI components are authorized for use in FDA Class III (or similar life-critical medical equipment) unless authorized officers of the parties have executed a special agreement specifically governing such use.

Only those TI components which TI has specifically designated as military grade or “enhanced plastic” are designed and intended for use in military/aerospace applications or environments. Buyer acknowledges and agrees that any military or aerospace use of TI components which have **not** been so designated is solely at the Buyer’s risk, and that Buyer is solely responsible for compliance with all legal and regulatory requirements in connection with such use.

TI has specifically designated certain components as meeting ISO/TS16949 requirements, mainly for automotive use. In any case of use of non-designated products, TI will not be responsible for any failure to meet ISO/TS16949.

### Products

Audio	<a href="http://www.ti.com/audio">www.ti.com/audio</a>
Amplifiers	<a href="http://amplifier.ti.com">amplifier.ti.com</a>
Data Converters	<a href="http://dataconverter.ti.com">dataconverter.ti.com</a>
DLP® Products	<a href="http://www.dlp.com">www.dlp.com</a>
DSP	<a href="http://dsp.ti.com">dsp.ti.com</a>
Clocks and Timers	<a href="http://www.ti.com/clocks">www.ti.com/clocks</a>
Interface	<a href="http://interface.ti.com">interface.ti.com</a>
Logic	<a href="http://logic.ti.com">logic.ti.com</a>
Power Mgmt	<a href="http://power.ti.com">power.ti.com</a>
Microcontrollers	<a href="http://microcontroller.ti.com">microcontroller.ti.com</a>
RFID	<a href="http://www.ti-rfid.com">www.ti-rfid.com</a>
OMAP Applications Processors	<a href="http://www.ti.com/omap">www.ti.com/omap</a>
Wireless Connectivity	<a href="http://www.ti.com/wirelessconnectivity">www.ti.com/wirelessconnectivity</a>

### Applications

Automotive and Transportation	<a href="http://www.ti.com/automotive">www.ti.com/automotive</a>
Communications and Telecom	<a href="http://www.ti.com/communications">www.ti.com/communications</a>
Computers and Peripherals	<a href="http://www.ti.com/computers">www.ti.com/computers</a>
Consumer Electronics	<a href="http://www.ti.com/consumer-apps">www.ti.com/consumer-apps</a>
Energy and Lighting	<a href="http://www.ti.com/energy">www.ti.com/energy</a>
Industrial	<a href="http://www.ti.com/industrial">www.ti.com/industrial</a>
Medical	<a href="http://www.ti.com/medical">www.ti.com/medical</a>
Security	<a href="http://www.ti.com/security">www.ti.com/security</a>
Space, Avionics and Defense	<a href="http://www.ti.com/space-avionics-defense">www.ti.com/space-avionics-defense</a>
Video and Imaging	<a href="http://www.ti.com/video">www.ti.com/video</a>

### TI E2E Community

[e2e.ti.com](http://e2e.ti.com)