

LITHIUM MANGANESE DIOXIDE BATTERY

SPECIFICATIONS

Model	:	CR14250
Description	:	Manganese Dioxide Lithium Battery (LiMnO ₂)
Nominal Capacity	:	600mAh
Nominal Voltage	:	3.0 V
Cut-Off Voltage	:	2.0 V
Weight	:	10 g
Shelf-Life	:	6 years ex-factory
Recommended Drain	:	Standard : 5mA Continuous < 500mA Pulse < 1000mA
Operating Temperature Range	:	-20 to +60 degree C
Service Life	:	Typ. 550hrs at 1mA continuous discharge Typ. 120hrs at 5mA continuous discharge Typ. 9.5hrs at 50mA continuous discharge
Warning	:	Do not short circuit. Do not recharge. Do not overdischarge. Do not disassemble. Do not put on fire. Do not inverse polarity. Do not mix new and old battery. Do not mix with different battery

Typical Discharge Characteristics

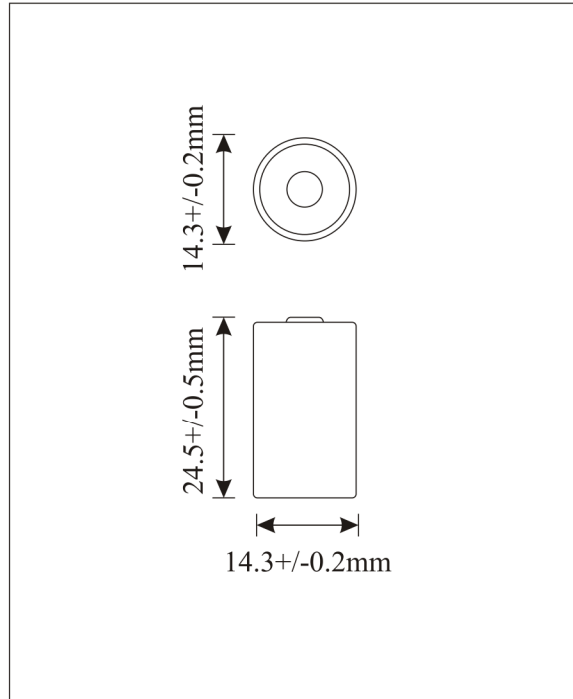
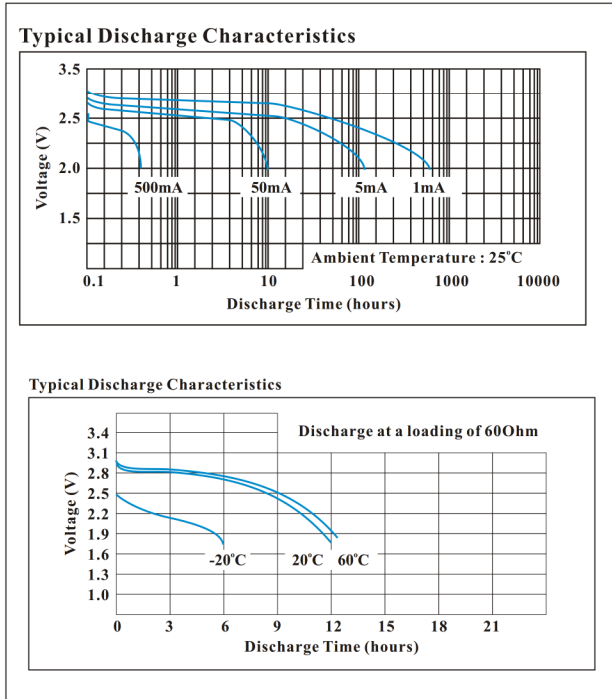

Information is for references only.