

KS10A 800V series Bi-directional triode thyristor

Features

- Hermetic ceramic -metal seal
- high dv/dt
- tested according to IEC standards
- High surge capability
- Compression Bonded Encapsulation for heavy duty operations such as severe thermal cycling

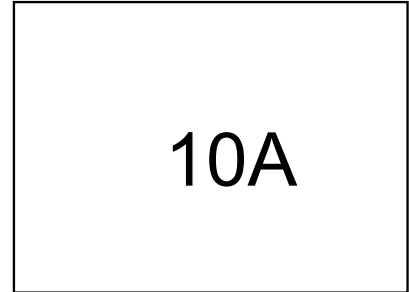

Typical Applications

- DC motor controls
- Controlled DC power supplies
- AC controllers

Major Ratings and Characteristics

Parameters	KS10A	Units
$I_{T(AV)}$	10	A
$@ T_c$	90	°C
$I_{T(RMS)}$	24	A
I_{TSM} @ 50Hz	2.7	A
$@ 60Hz$	2.83	A
$I^2 t$ @ 50Hz	36.4	KA ² s
$@ 60Hz$	33.2	KA ² s
V_{DRM} / V_{RRM}	800	V
T_q typical	300	μs
T_J range	- 40 to 125	°C

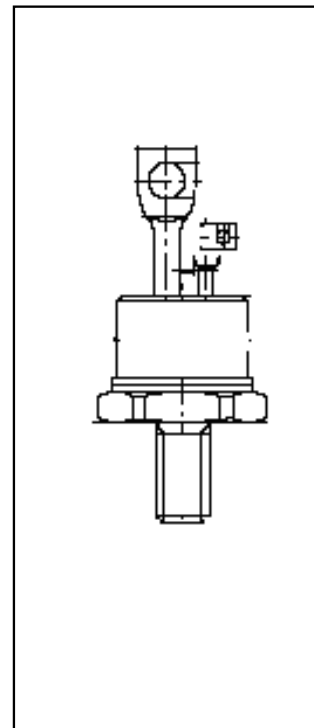

ELECTRICAL SPECIFICATIONS

Voltage Ratings

Type number	Voltage Code	V_{RRM} / V_{DRM} , maximum repetitive peak reverse voltage V	V_{RSM} , maximum non-repetitive peak rev. voltage V	I_{RRM} / I_{DRM} max. @ $T_J = T_J$ max. mA
KS10A	02	200	300	20
	06	600	700	
	10	1000	1100	
	12	1200	1300	
	15	1500	1600	

On-state Conduction

Parameter	KS10A	Units	Conditions		
$I_{T(AV)}$ Maximum average on-state current @ Case temperature	10A	A	180° conduction, half sine wave		
	90	°C			
$I_{(RMS)}$ Maximum RMS on-state current	24	A	180° conduction, half sine wave @ $T_C = 80^\circ C$		
I_{TSM} Maximum peak, one-cycle non-repetitive surge current	2700	A	t = 10ms	No voltage	Sinusoidal half wave, Initial T = T max.
	2830		t = 8.3ms	reapplied	
	2270		t = 10ms	100% V_{RRM}	
	2380		t = 8.3ms	reapplied	
$I^2 t$ Maximum $I^2 t$ for fusing	36.4	KA ² s	t = 10ms	No voltage	
	33.2		t = 8.3ms	reapplied	
	25.8		t = 10ms	100% V_{RRM}	
	23.5		t = 8.3ms	reapplied	
$I^2 \sqrt{t}$ Maximum $I^2 \sqrt{t}$ for fusing	364	KA ² √s	t = 0.1 to 10ms, no voltage reapplied		
V_{TM} Maximum on-state or forward	1.52	V	pk = 600A, $T_J = 25^\circ C$, t p = 10ms sine pulse		
I_H Maximum holding current	600	mA	$T_J = 25^\circ C$, anode supply 12V resistive load		
I_L Typical latching current	1000				

Switching

Parameter	KS10A	Units	Conditions
di/dt ax. non-repetitive rate of rise of turned-on current	500	A/μs	Gate drive 20V, 20Ω, tr ≤ 1μs $T_J = T_J$ max, anode voltage ≤ 80% V_{DRM}
td ical delay time	2.0	μs	Gate current 1A, dig/dt = 1A/μs $V_d = 0.67\% V_{DRM}$, $T_J = 25^\circ C$
Tq ical turn-off time	100	μs	$I_{TM} = 300A$, $T_J = T_J$ max, di/dt = 20A/μs, $V_R = 50V$ dv/dt = 20V/μs, Gate 0V 100Ω, t p = 500μs

Blocking

Parameter	KS10A	Units	Conditions
dv/dt Maximum critical rate of rise of off-state voltage	500	V/μs	T _J = T _J max linear to 80% rated V _{DRM}
I _{DRM} Max. peak reverse and off-state leakage current	20	mA	T _J = T _J max, rated V _{DRM} /V _{RRM} applied

Triggering

Parameter	KS10A	Units	Conditions
G _M Maximum peak gate power	5	W	T _J = T _J max, t _p ≤ 5ms
G _(AV) Maximum average gate power	1.0		T _J = T _J max, f = 50Hz, d% = 50
I _{GM} Max. peak positive gate current	2.0	A	T _J = T _J max, t _p ≤ 5ms
+V _{GM} Maximum peak positive gate voltage	20	V	T _J = T _J max, t _p ≤ 5ms
-V _{GM} Maximum peak negative gate voltage	5.0		
I _{GT} DC gate current required to trigger	TYP.	MAX.	T _J = - 40°C T _J = 25°C T _J = 125°C Max. required gate trigger/ current/ voltage are the lowest value which will trigger all units 12V anode-to-cathode applied
	180	-	
	90	150	
V _{GT} DC gate voltage required to trigger	2.9	-	T _J = - 40°C T _J = 25°C T _J = 125°C
	1.8	30	
	1.2	-	
I _{GD} DC gate current not to trigger	8	mA	T _J = T _J max Max. gate current/ voltage not to trigger is the max. value which will not trigger any unit with rated V anode-to-cathode applied
V _{GD} DC gate voltage not to trigger	0.25	V	

Thermal and Mechanical Specification

Parameter	KS10A	Units	Conditions
T _J Max. operating temperature range	-40 to 125	°C	
T _{stg} Max. storage temperature range	-40 to 150		
R _{thJC} Max. thermal resistance, junction to case	0.195	K/W	DC operation
R _{thCS} Max. thermal resistance, case to heatsink	0.08		Mounting surface, smooth, flat and greased
T Mounting torque, ± 10%	15.5(137)	Nm	Non lubricated threads
	14(120)	(lbf-in)	Lubricated threads
wt Approximate weight	0.03	Kg	

Outline Table

1

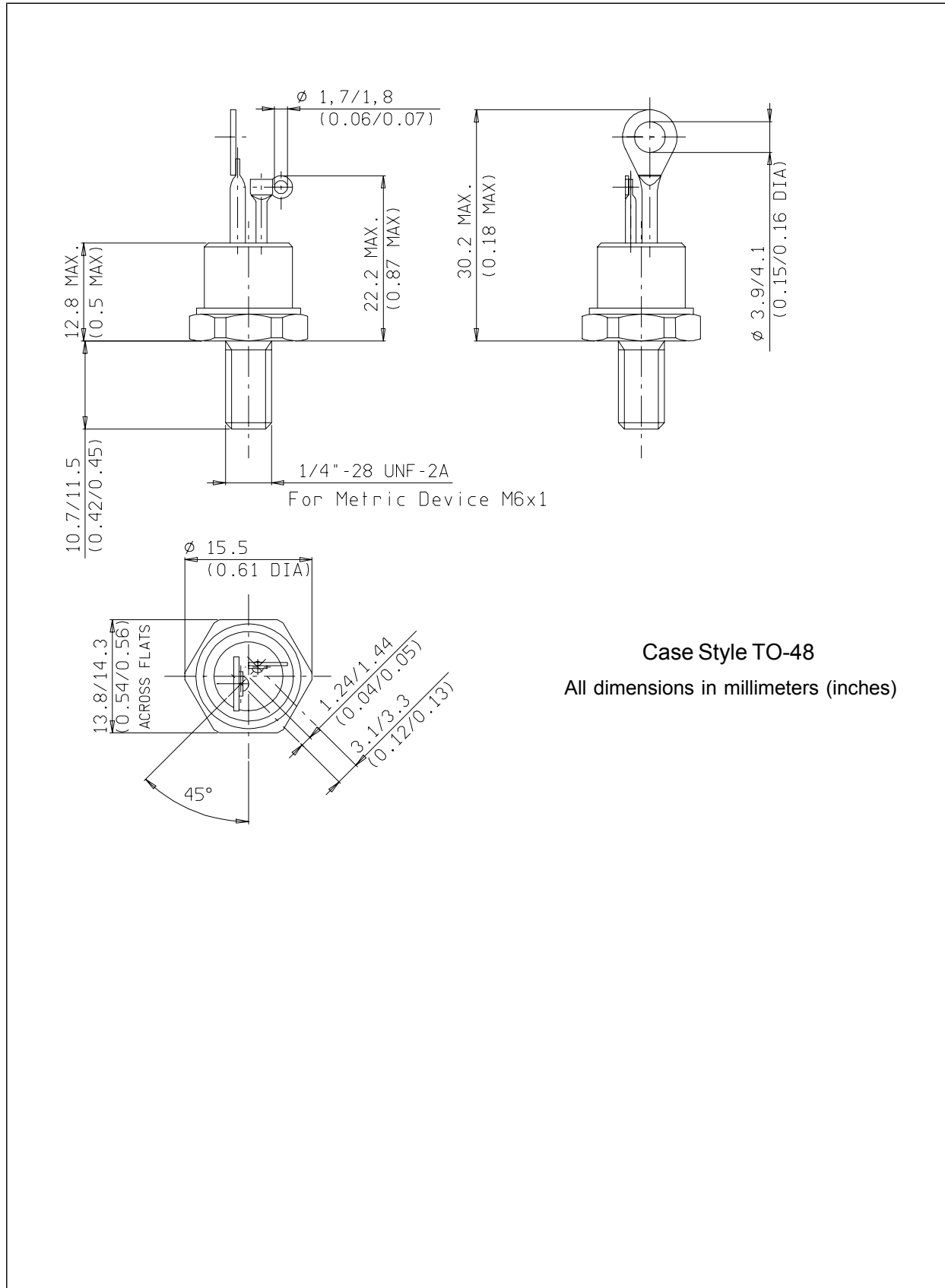

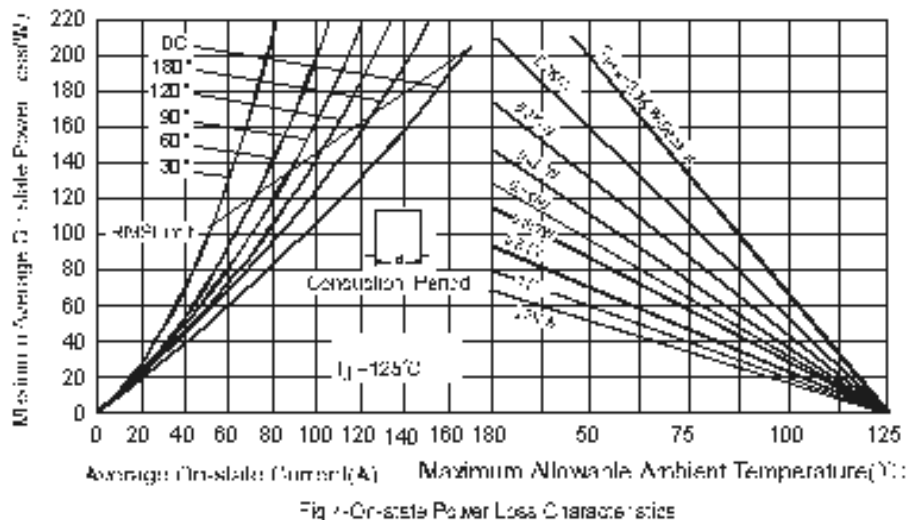
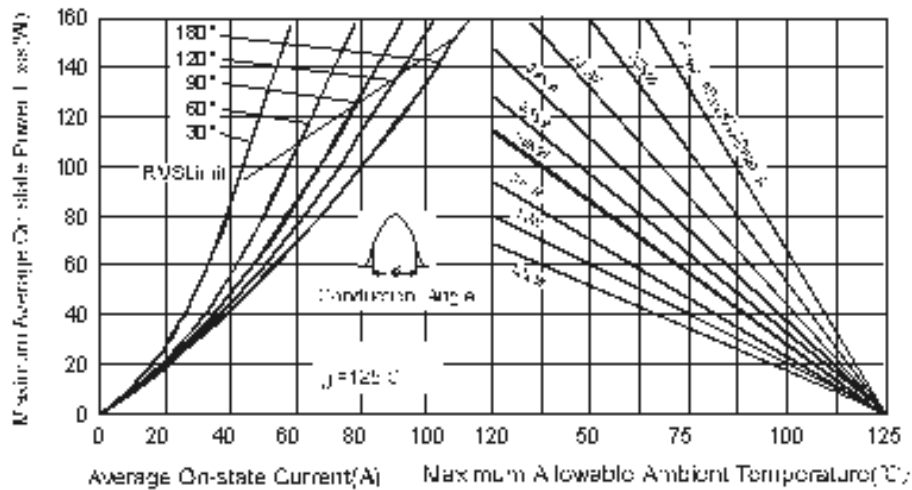
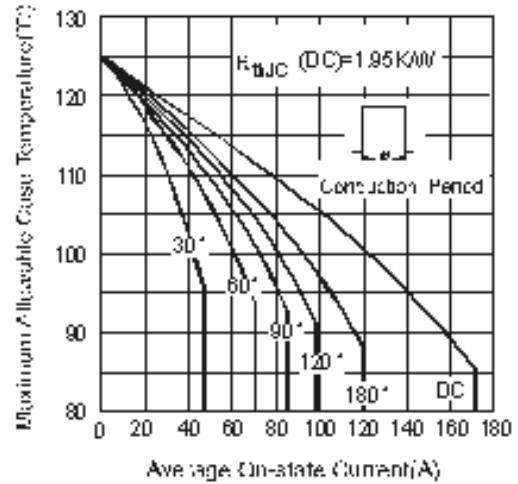
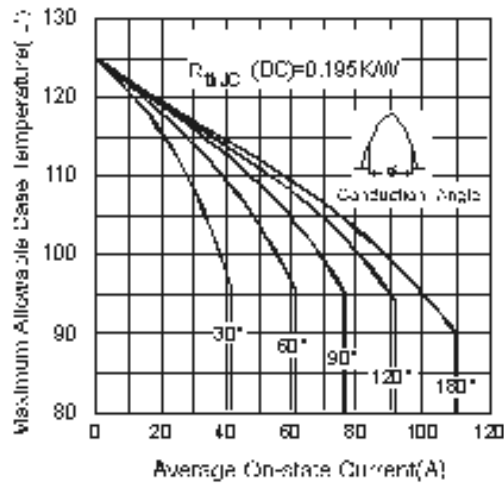

1

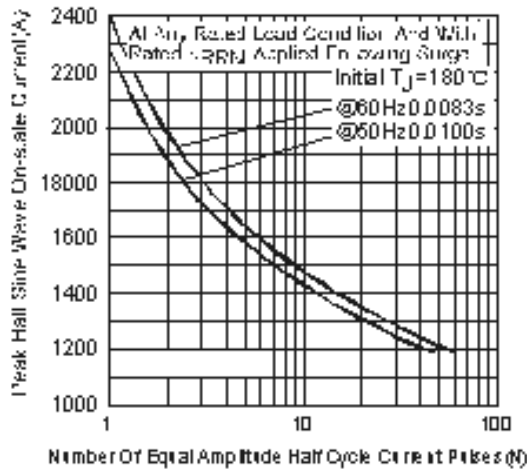

Fig.5-Maximum Non-Repetitive Surge Current

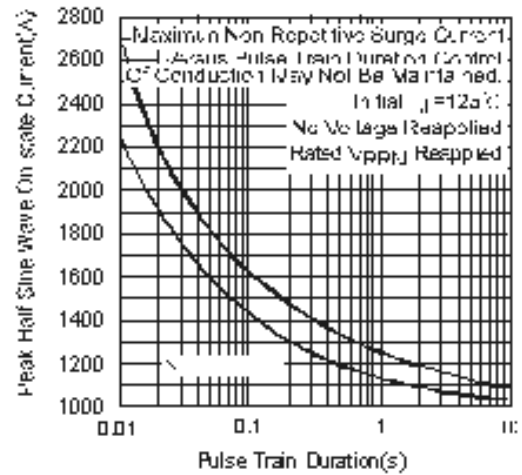

Fig.6-Maximum Non-Repetitive Surge Current

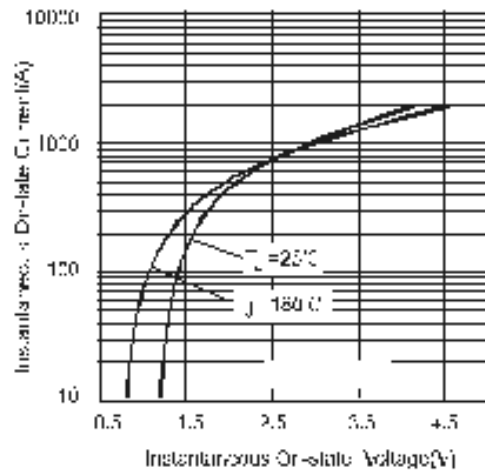

Fig.7-On-state Voltage Drop Characteristics

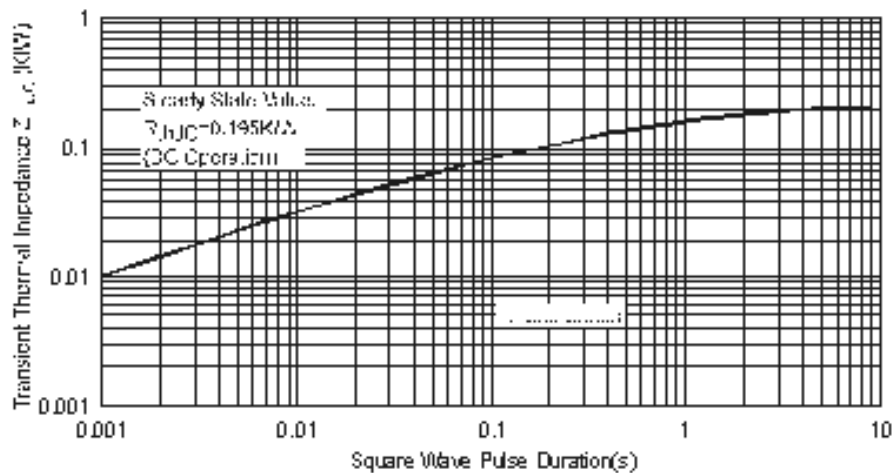

Fig.8-Thermal Impedance Z_{thJC} Characteristics