

Order Information

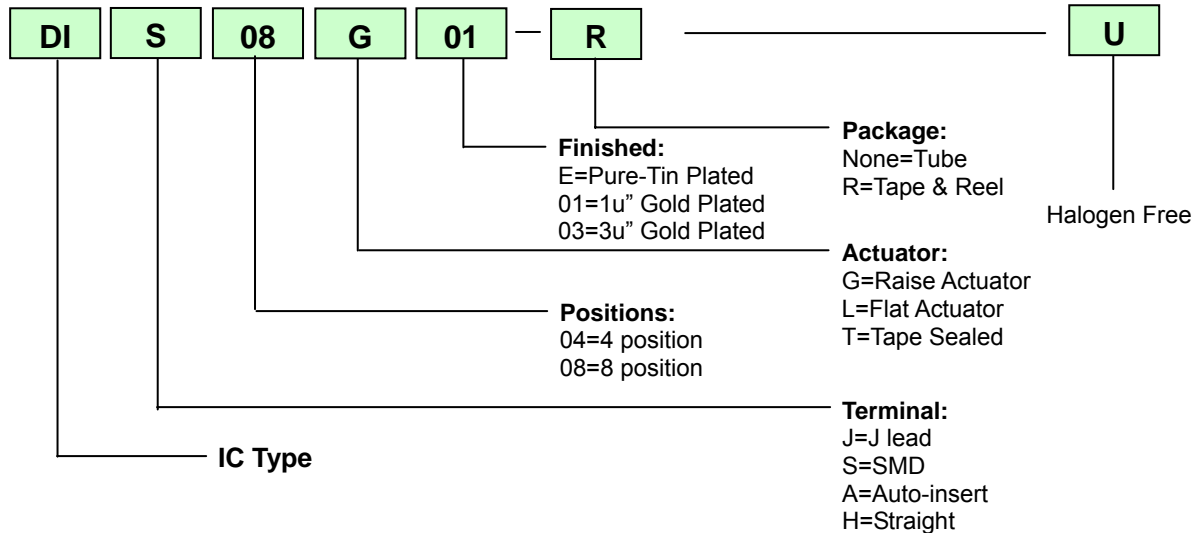

Specifications

◆ Contact Rating	Switching.....	25mA, 24VDC
	Non-Switching.....	100mA, 50VDC
◆ Contact Resistance	Initial.....	.50mΩ Max.
	After Reliability Test.....	100mΩ Max.
◆ Insulation Resistance	100MΩ Min. at 500VDC
◆ Dielectric Strength	500VDC / 1 minute
◆ Operation Force	1,000g max
◆ Travel :	0.9mm
◆ Mechanical Life	5,000 cycles (Min.)
◆ Electrical Life	2,000 cycles / 25mA, 24VDC
◆ Operation Temperature	-40 ~ +85
◆ Storage Temperature	-40 ~ +85

MODEL	SPECIFICATION RoHS Compliant DIP SWITCH	SP-002	Page
DI series IC Type			2/10

Soldering Information

◆ **Hand Soldering**

Soldering iron 30W or under at 350 for 3 sec max or at 270 for 5 sec max.

◆ **Reflow Soldering**

(1) Gold-plated series available 2~3 times process

(2) Tin-plated series available 1 time process

(3) Vapor Phase Heating (VPH) switch must with Tape sealed type

◆ **Wave Soldering**

For lead free wave solder simulation of typical components, the solder bath temperature Shall be maintained to 275 .

The hold time in the solder shall be 10 +2/-0 seconds.

◆ **Keep all actuators in " OFF " position during cleaning process.**

Classification Reflow Profiles

Profile Feature	Pb-Free Assembly
Preheat / Soak	
Temperature Min (T_{smin})	150
Temperature Max (T_{smax})	200
Time(ts) from (T_{smin} to T_{smax})	60 ~120 seconds
Ramp-up Rate (T_L to T_p)	3 /second max
Liquidous temperature (T_L)	217
Time (t_L) maintained aboe to T_L	60 ~ 150 seconds
Peak package body temperature (T_p)	For users T_p must not exceed the Classification temp:260 (Package Thickness:>2.5mm) For supilers T_p must equal or exceed the Classification temp:250 (Package Thickness:>2.5mm)
Time (t_p) within 5 of specified classification Temperature (T_c)	30 seconds
Ramp-Down Rate (T_p to T_L)	6 /second max
Time 25 to Peak Temperature	8 minutes max
*Tolerance for peak profile temperature(T_p) is defined as a supplier minimum and a user maximum	

Note 1: All temperatures refer to topside of the package, measured on the package body surface.

Note 2: Time within 5 °C of actual peak temperature (t_p) specified for the reflow profiles is a “supplier” minimum and “user” maximum.

The table copy from IPC/JEDEC J-STD-020 D.1

Reflow Soldering Standard Conditions

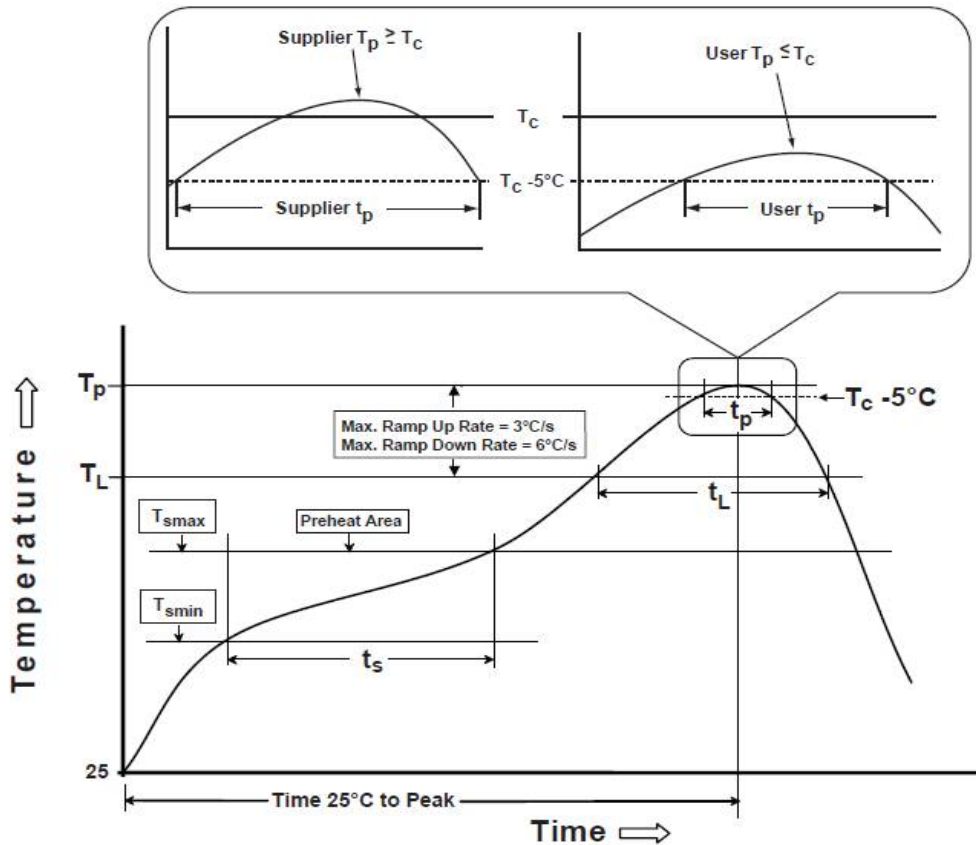

MODEL	SPECIFICATION RoHS Compliant DIP SWITCH	SP-004	Page
DI series IC Type			4/10

Classification Wave Soldering Profiles

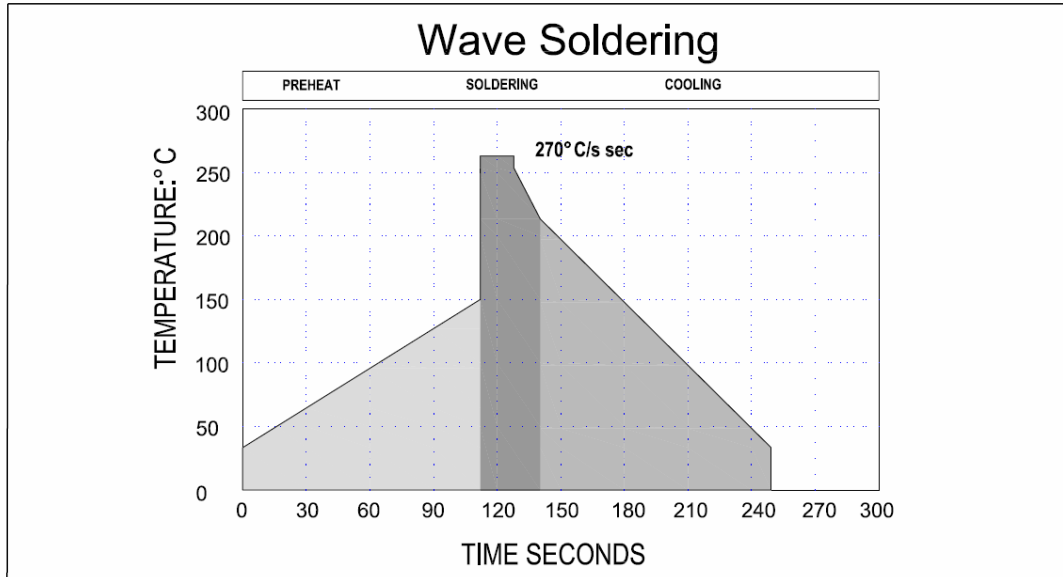

Maximum dwell time in the solder wave (270) shall not exceed 5 seconds.

Switch Operation and Taping

- (1) Use tweezers or ball-point pen for operation.
- (2) Flux cleaning should be done without removing the Tape.
- (3) If the tape is removed, it adheres less than before when it is placed back on, possibly causing flux inflow
- (4) Do Not Remove Tape sealed before Reflow processing
- (5) Ultrasonic cleaning not re-commended without Tape sealed..

All switches must set in OFF position when through Soldering process.
Any flux enters the switch may influence contact function.

Materials

- ◆ CoverThermoplastic (UL 94V-0), Black
- ◆ BaseThermoplastic (UL 94V-0), Black
- ◆ Actuator
DIS/DIJ.....Thermoplastic (UL 94V-0), White
DIA/H.....Thermoplastic (UL 94V-0), White
- ◆ Terminal ContactGold Plated / Pure-Tin Plated
- ◆ Movable ContactGold Plated / Pure-Tin Plated
- ◆ Terminal40u" +/-10u" Nickel Cover (Pure) Tin-Plated
.....40u" +/-10u" Nickel Cover 1u" Gold-Plated
.....40u" +/-10u" Nickel Cover 3u" Gold-Plated
- ◆ TapePolyimide Film

DIJ

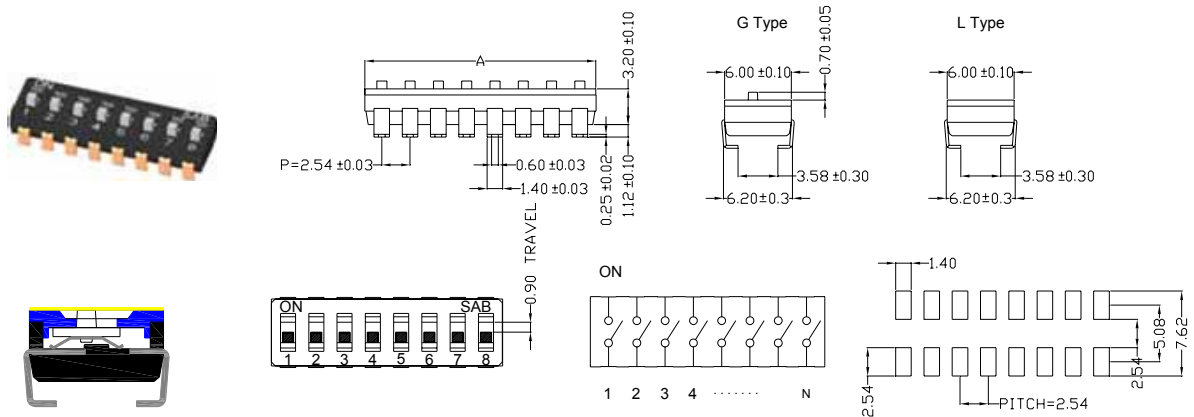

DIS

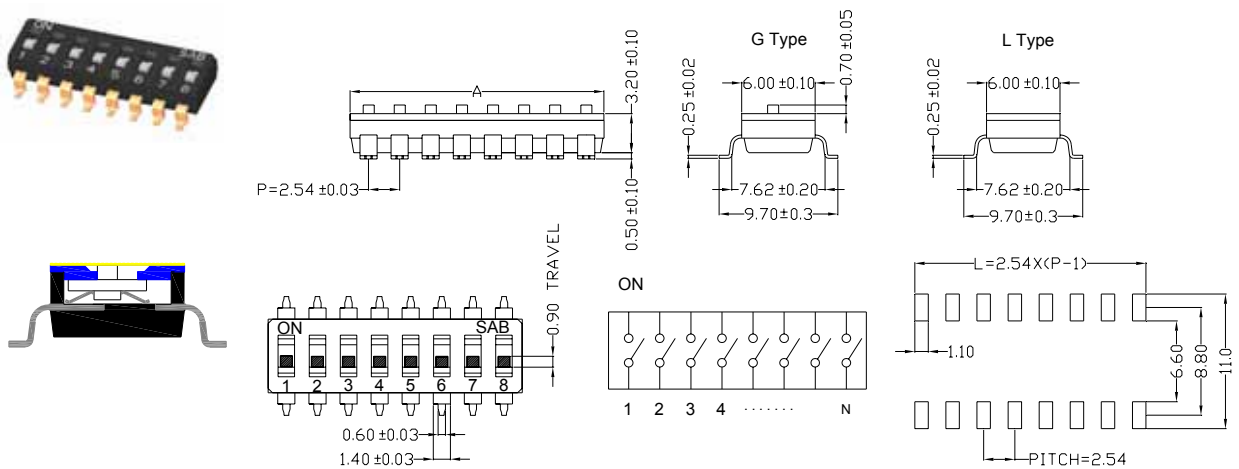

MODEL	SPECIFICATION RoHS Compliant DIP SWITCH	SP-006	Page
DI series			6/10
IC Type			

DIA/H

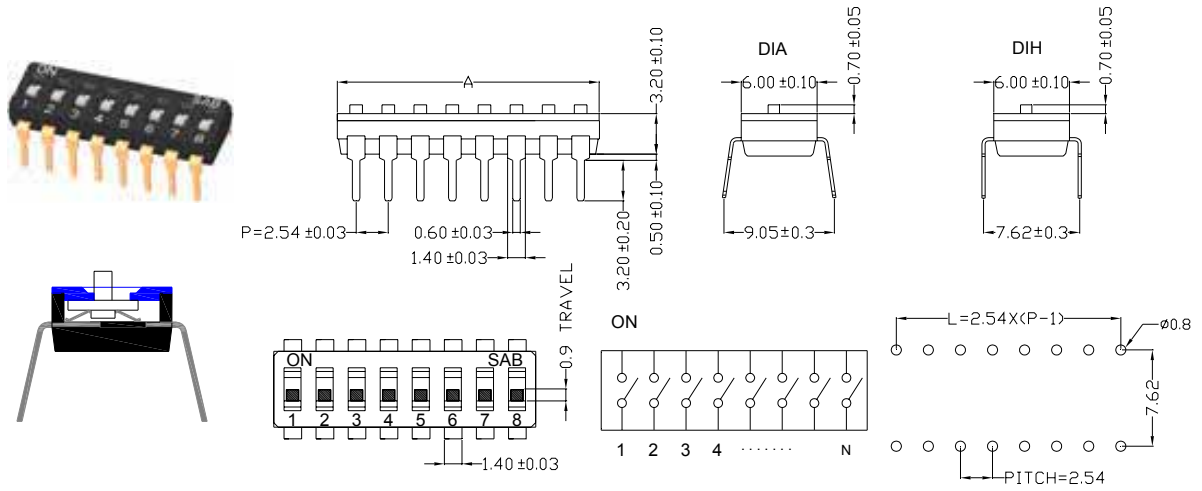

Part Number Table

No. Pos.	Dim. "A"	Auto Insert	SMD	J Lead
		Pure-Tin Lead Raise Actuator Tube Package	1u" Gold Lead Flat Actuator Tube Package	3u' Gold Lead Tape Sealed Tape Reel
1	2.98	DIA01GE	DIS01L01	DIJ01T03-R
2	5.52	DIA02GE	DIS02L01	DIJ02T03-R
3	8.06	DIA03GE	DIS03L01	DIJ03T03-R
4	10.60	DIA04GE	DIS04L01	DIJ04T03-R
5	13.14	DIA05GE	DIS05L01	DIJ05T03-R
6	15.68	DIA06GE	DIS06L01	DIJ06T03-R
7	18.22	DIA07GE	DIS07L01	DIJ07T03-R
8	20.76	DIA08GE	DIS08L01	DIJ08T03-R
9	23.30	DIA09GE	DIS09L01	DIJ09T03-R
10	25.84	DIA10GE	DIS10L01	DIJ10T03-R
12	30.92	DIA12GE	DIS12L01	DIJ12T03-R

MODEL	SPECIFICATION RoHS Compliant DIP SWITCH	SP-007	Page
DI series			7/10
IC Type			

Tube Package

POLE	1	2	3	4	5	6	7	8	9	10	12
TUBE	174	95	65	48	39	33	28	25	22	20	17
BOX	17400	9500	6500	4800	3900	3300	2800	2500	2200	2000	1700
CTN 1	34800	19000	13000	9600	7800	6600	5600	5000	4400	4000	3400
CTN 2	69600	38000	26000	19200	15600	13200	11200	10000	8800	8000	6800

DIS

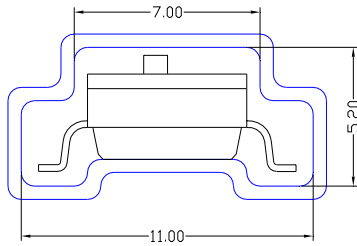

DIA/H

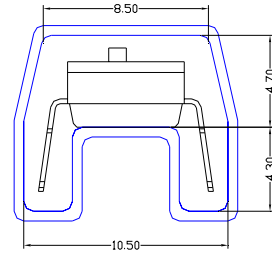

Tape & Reel package

◆ DIS

POLE	01	02	03	04	05	06	07	08	09	10	12
Pitch (mm)	8	8	16	16	16	16	16	16	16	16	16
Width (mm)	16	16	16	24	24	24	32	32	44	44	44
G type / Reel	1500	1500	800	800	800	800	800	800	800	800	800
L type / Reel	2000	2000	1000	1000	1000	1000	1000	1000	1000	1000	1000

◆ DIJ

POLE	01	02	03	04	05	06	07	08	09	10	12
Pitch (mm)	8	12	12	12	12	12	12	12	12	12	12
Width (mm)	16	16	16	24	24	24	32	32	44	44	44
G type / Reel	1400	900	900	900	900	900	900	900	900	900	900
L type / Reel	1600	1100	1100	1100	1100	1100	1100	1100	1100	1100	1100

DIS01/DIS02

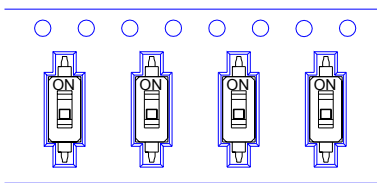

DIS03~12

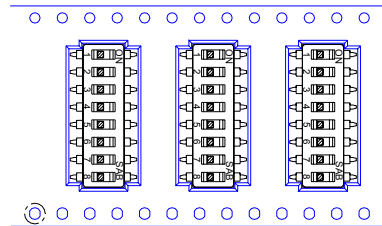

DIJ01/DIJ02

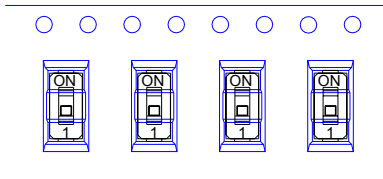

DIJ03~12

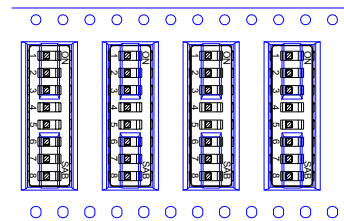

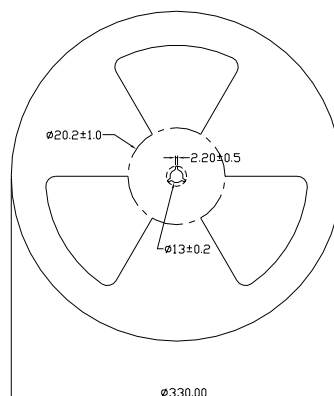
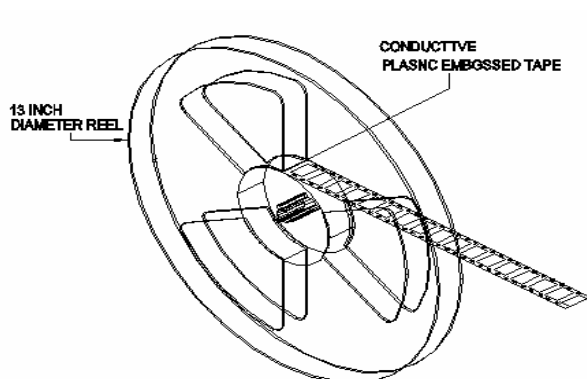
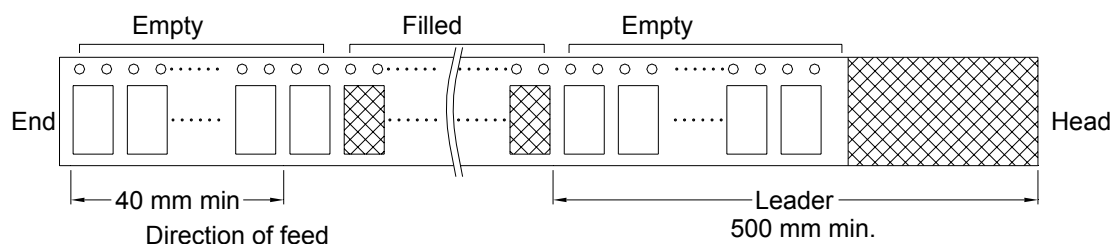

Carry Tape Table:

P/N.	Pitch(mm)	Thickness(mm)	Width (mm)	Sellotape(mm)	@REEL/BOX	Q'ty/Reel
DIS01	8	0.35	16	13.3	6	1500(G)/2000(L)
DIS02	8	0.35	16	13.3		1500(G)/2000(L)
DIS03	16	0.35	16	13.3		800(G)/1000(L)
DIS04	16	0.35	24	21.3	4	800(G)/1000(L)
DIS05	16	0.35	24	21.3		800(G)/1000(L)
DIS06	16	0.35	24	21.3		800(G)/1000(L)
DIS07	16	0.35	32	25.5	3	800(G)/1000(L)
DIS08	16	0.35	32	25.5		800(G)/1000(L)
DIS09	16	0.4	44	37.5	2	800(G)/1000(L)
DIS10	16	0.4	44	37.5		800(G)/1000(L)
DIS12	16	0.4	44	37.5		800(G)/1000(L)

MODEL	SPECIFICATION RoHS Compliant DIP SWITCH	SP-009	Page
DI series			9/10
IC Type			

16mm

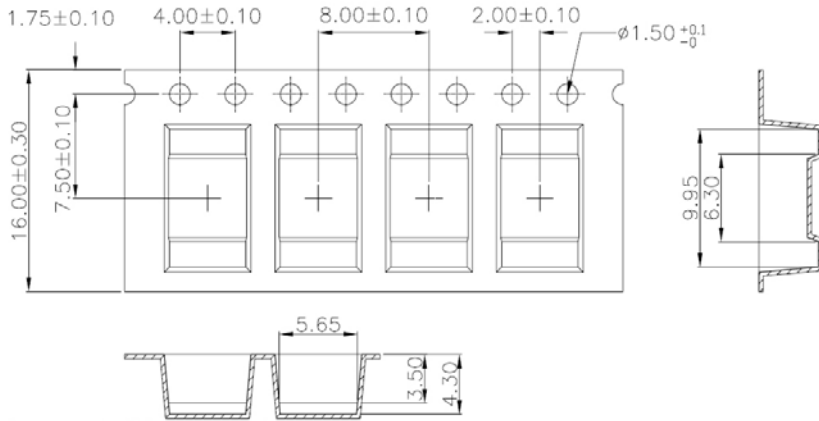

24mm

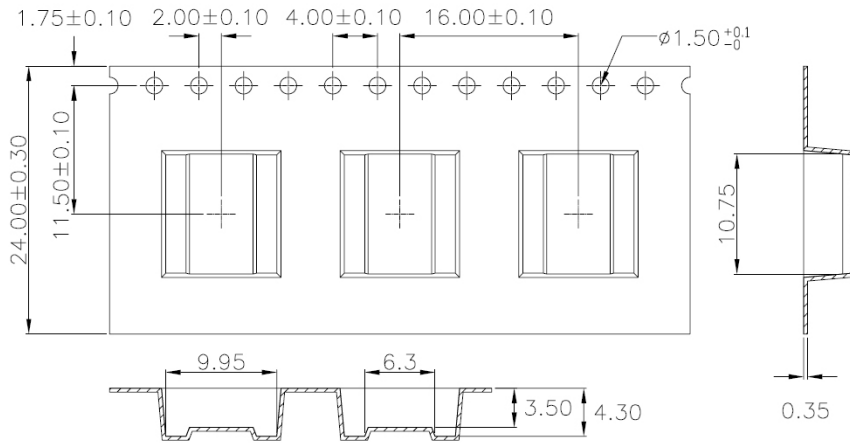

32mm

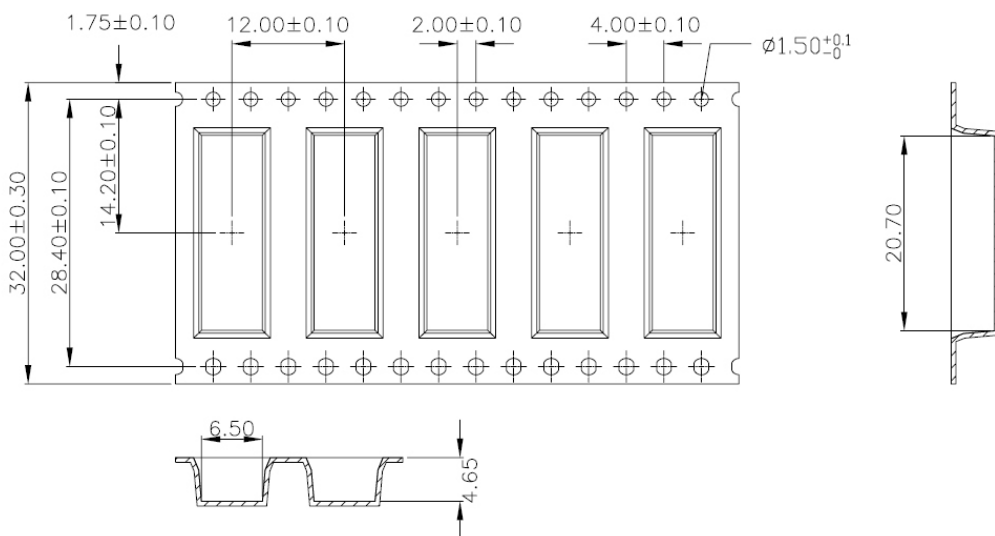

MODEL	SPECIFICATION RoHS Compliant DIP SWITCH	SP-0010	Page
DI series IC Type			10/10

44mm

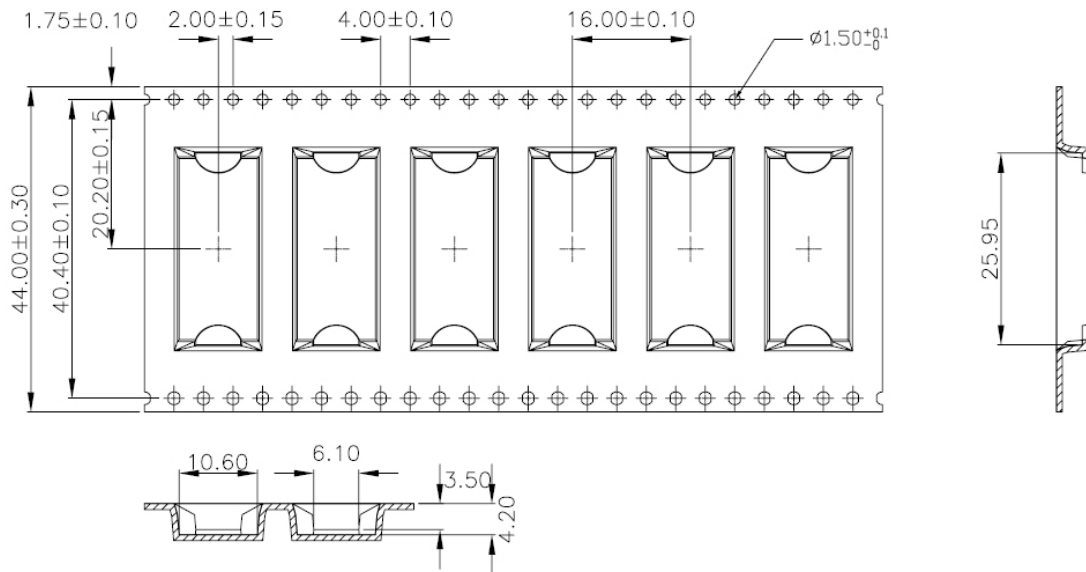

Box Dimension

- ◆ Tube57.0cm × 13.0cm × 12.5cm
- ◆ Tape & Reel34.5cm x 34.5cm x 15.0cm

Carton Dimension

- ◆ Tube CTN1 / 2 Boxes.....58.5cm x 29.0cm x 15.0cm
- CTN2 / 4 Boxes.....58.5cm x 28.0cm x 27.0cm
- ◆ Tape & Reel CTN1 / 1 Box.....34.5cm x 34.5cm x 15.0cm
- CTN1 / 2 Boxes.....36.0cm x 27.5cm x 37.0cm