

SECTION C-C

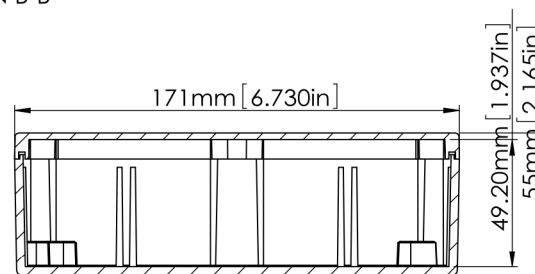
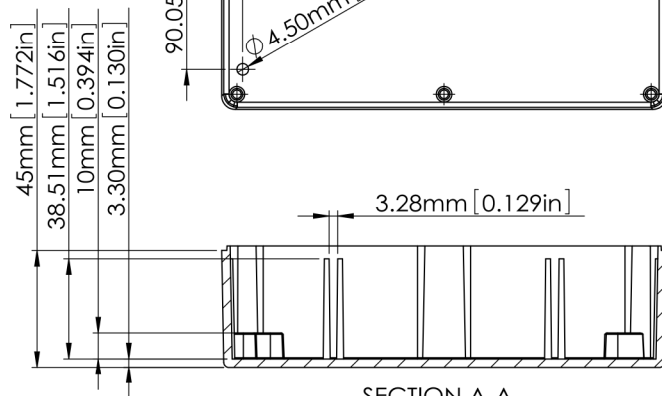
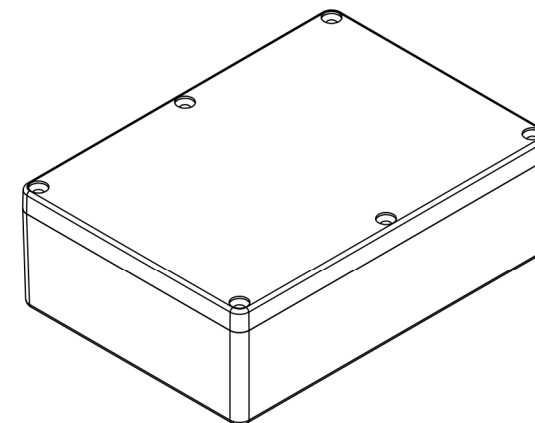
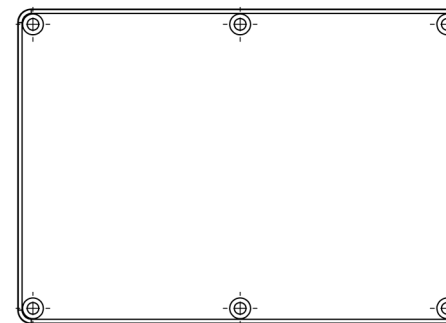
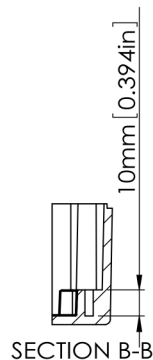
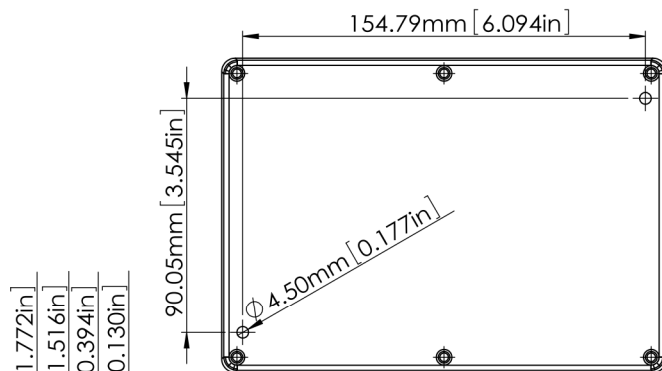

According to ISO 2768-m	
Measuring DIM=L	Tolerances
0.5<L<=3.0mm	±0.1mm
3.0<L<=6.0 mm	±0.1mm
6.0<L<=30.0 mm	±0.2mm
30.0<L<=120.0 mm	±0.3mm
120.0<L<=400.0 mm	±0.5mm
400.0<L<=1000.0 mm	±0.8mm

宣又實業有限公司
 GAINTA INDUSTRIES LTD.

繪圖 DRA'D BY
 JACKY

日期 DATE
 2010/12/31

材質 MATE.
 ALUMINIUM ALLOY ADC-12

圖名TITLE:
 G120

圖號DWG NO:

版次REVISID:
 D