

Switch

Slide Switch Series

KLS7-SS02-12F20 (1P2T) Slide Switch Series

SPECIFICATIONS

- Rating: 0.5A 50VDC
- Contact Resistance: 50MΩ max
- Insulation Resistance: 500VDC 100MΩ Min
- Dielectric Strength: 100V AC 1 Minute
- Operating Force: 100gf~800gf
- Electrical Life : 10,000 cycles



VII

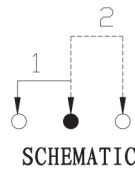
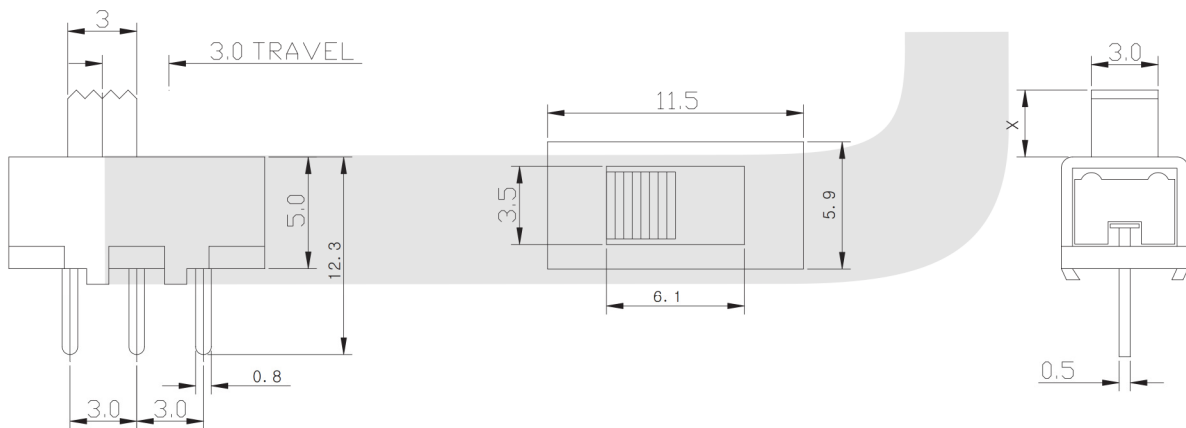

ORDER INFORMATION

KLS7-SS02 - 1 2 F 20 - X X - X

Part Number

Slide Switch Type

Pole

Throw

| Travelling | | | | | |
|------------|-----|-----|-----|-----|-----|
| C | D | E | F | G | H |
| 1.5 | 2.0 | 2.5 | 3.0 | 3.5 | 4.0 |
| I | J | K | L | N | P |
| 4.5 | 5.0 | 5.5 | 6.0 | 7.0 | 8.0 |

Operating Force

Knobe Height

Sequential No.

Knob Type

