

### ACT9200 HCMOS/TTL Surface Mount SPXO

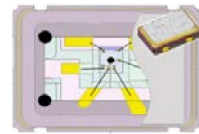

- Stability:  $\pm 10\text{ppm} \sim \pm 100\text{ppm}$
- Supply Voltage: 3.3V, 5.5V
- Tristate: Enable high option available,
- Construction: Seam sealed ceramic 4 pad with grounded lid.



#### Characteristics

Frequency Range (MHz)	1 ~ 200 (3.3V), 1 ~ 40 (5.0V)
Supply voltage $\pm 5\% V_{cc} (V_{dc})$	3.3, 5.0
Operating Current mA max	Table 1
Operating temperature Top ( $^{\circ}\text{C}$ )	Table 2
Stability all causes*	Table 2
Aging @25 $^{\circ}\text{C}$ (ppm)	$\pm 5$ ( $\pm 3$ option)
Load $\pm 10\%$	10TTL/15pF HCMOS (30pF option)
Output voltage	VOH 2.4V min -TTL, 90%Vcc min-HCMOS VOL 0.4V max - TTL, 10%Vcc max- HCMOS
Duty Cycle	45/55%
Start up time	10ms max
Rise/fall times ns (max)	10 -1~34.9MHz, 5 - 35~99.9MHz, 2.5-100~200MHz
Period Jitter	Table 3
Phase Noise	Fig 1

#### Rating

Storage temperature ( $^{\circ}\text{C}$ )	-55 ~ 125
MSL	1 unlimited
ESD	Take appropriate precautions

#### Notes:

\*Stability all causes : Tolerance+Stability over temperature+Aging+Load+Vcc

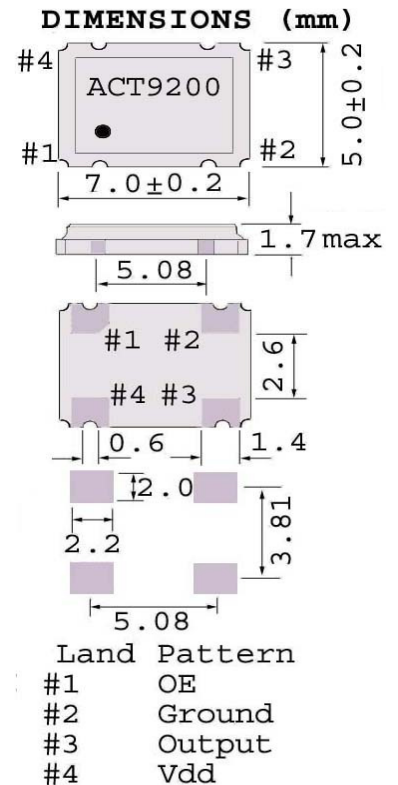

**Table 2 Available Stabilities (all causes in ppm)**

	$\pm 15$	$\pm 20$	$\pm 25$	$\pm 30$	$\pm 50$	$\pm 100$
0~50 $^{\circ}\text{C}$	✓	✓	✓	✓	✓	✓
0~60 $^{\circ}\text{C}$	✓	✓	✓	✓	✓	✓
-10~60 $^{\circ}\text{C}$	✓	✓	✓	✓	✓	✓
0~70 $^{\circ}\text{C}$		✓	✓	✓	✓	✓
-10~70 $^{\circ}\text{C}$		✓	✓	✓	✓	✓
-20~70 $^{\circ}\text{C}$		✓	✓	✓	✓	✓
-40~85 $^{\circ}\text{C}$			✓	✓	✓	✓

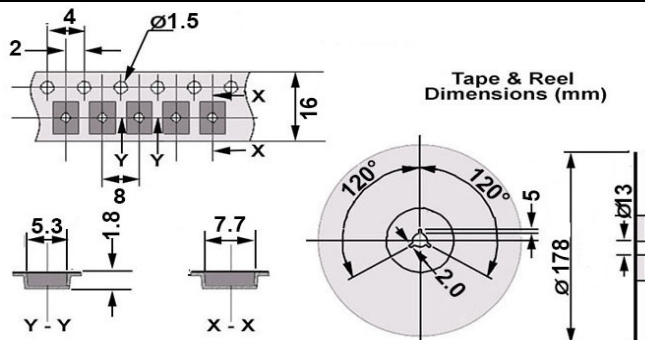
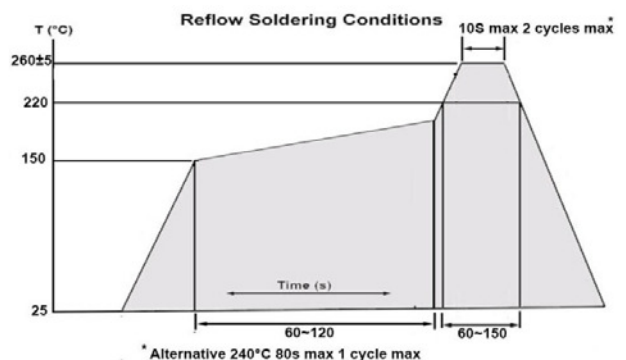

**Table 1: Iop max**

1~34.999MHz	16 mA
35~60MHz	25 mA
60.001~99.999MHz	40 mA
100~155MHz	50 mA
155.01~200MHz	60 mA

Please note that all parameters can not necessarily be specified in the same device.  
 To specify: Please refer to part numbering system appended to the end of this data

ISO9001 Registered

For quotations or further information please contact us at:  
 3 The Business Centre, Molly Millars Lane, Wokingham, Berkshire, RG41 2EY  
 Issue No. 12 Skr Date:

ACT9200 HCMOS/TTL Surface Mount SPXO

Table 3 Jitter	RMS (1sigma)		Absolute (pk-pk)	
	Mean	Max	Mean	Max
1MHz		25ps		100ps
25MHz	6.3ps	10ps	17.8ps	28ps
33MHz	5.2ps	10ps	14.7ps	28ps
60MHz	3.7ps	5ps	10.5ps	14ps
100MHz	1ps	3ps	2.8ps	8.4ps

Test Circuits

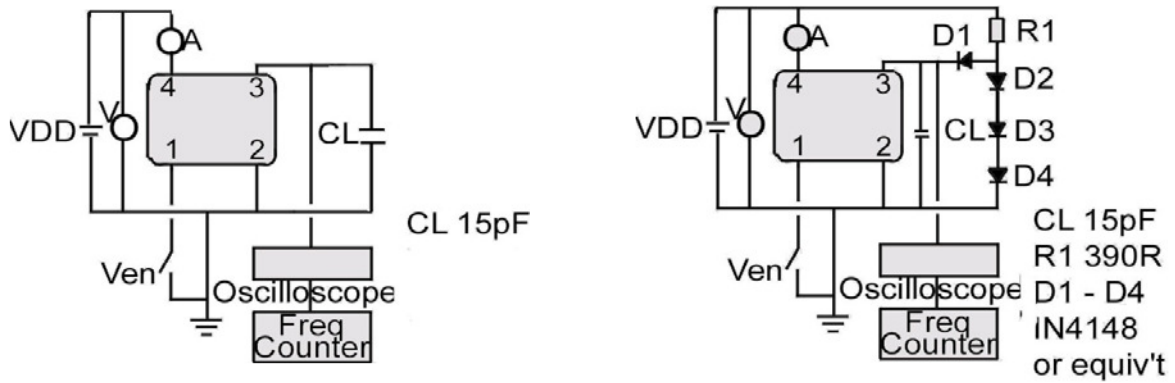
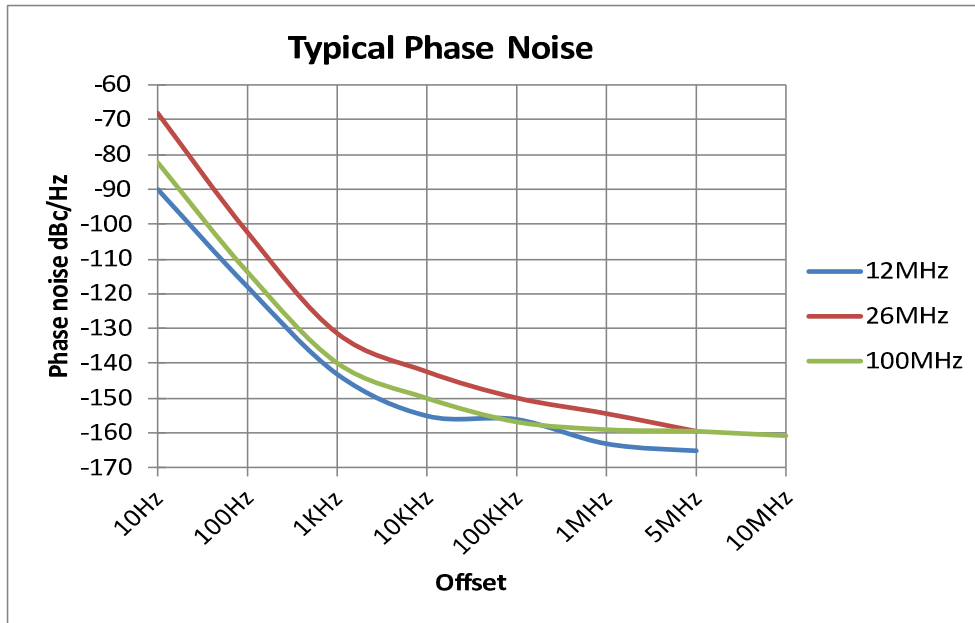

Fig 1



ACT9200 HCMOS/TTL Surface Mount SPXO

OCILLATOR PART NUMBERING

RV	2700	D	B	D	H	E	P	C	-PF
9200	27.00MHz	±15 ppm	3.3 V <sub>DC</sub>	0~50 °C	45/55 %/ %	HCMOS	Tristate	45/55	RoHS

9200	RV
------	----

Stability v All cause ±ppm	
15	D
20	I
25	C
30	H
50	B
100	A

T <sub>OP</sub> °C	
0~50	D
-10+60	F
0~70	E
-10+70	C
-20+70	B
-30+80	G
-40+85	I

Output	
HCMOS	E
HCMOS 30pF	Q
Universal TTL/HCMOS	J
TTL	H

Tristate	
Tristate	P
None	N

**Commodity code**

Frequency <1.8 or >67MHz  
854370 90 99

Frequency between 1.8 and 67 MHz  
854370 90 45

Standard

Duty Cycle % / %	
45/55	H

V <sub>CC</sub>	V <sub>DC</sub>
3.3	B
5	A

Tape & Reel	
1K Reel	C
Loose	L

**Frequency:**  
 For part numbering use the first 4 characters of the frequency in Hz ie 27MHz = 27000000Hz so the code used in the part number is 2700. If the frequency is 100MHz or higher then the first 5 characters are used.  
 It is important to suffix the part number generated above with the actual frequency to give the full part number as illustrated below.

RV-2700DBDHEPC-PF 27.00MHz