

**NPN SILICON PLANAR SWITCHING TRANSISTORS**

**PN2222  
PN2222A  
CBE  
TO-92**

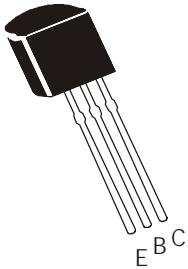

**Complementary Silicon Transistors For Switching And Linear Applications  
DC Amplifier & Driver For Industrial Applications.**

**ABSOLUTE MAXIMUM RATINGS(Ta=25deg C unless otherwise specified)**

DESCRIPTION	SYMBOL	2222	2222A	UNIT
Collector -Emitter Voltage	VCEO	30	40	V
Collector -Base Voltage	VCBO	60	75	V
Emitter -Base Voltage	VEBO	5.0	6.0	V
Collector Current Continuous	IC		600	mA
Power Dissipation @Ta=25 degC	PD		625	mW
Derate Above 25deg C			5	mW/deg C
@ Tc=25 degC	PD		1.5	W
Derate Above 25deg C			12	mW/deg C
Operating And Storage Junction Temperature Range	Tj, Tstg	-55 to +150		deg C
<b>THERMAL RESISTANCE</b>				
Junction to Case	Rth(j-c)		83.3	deg C/W
Junction to Ambient	Rth(j-a)		200	deg C/W

**ELECTRICAL CHARACTERISTICS (Ta=25 deg C Unless Otherwise Specified)**

DESCRIPTION	SYMBOL	TEST CONDITION	2222	2222A	UNIT	
Collector -Emitter Voltage	VCEO	IC=10mA, IB=0	>30	>40	V	
Collector -Base Voltage	VCBO	IC=10uA, IE=0	>60	>75	V	
Emitter-Base Voltage	VEBO	IE=10uA, IC=0	>5.0	>6.0	V	
Collector-Cut off Current	ICBO	VCB=50V, IE=0	<10	-	nA	
		VCB=60V, IE=0	-	<10	nA	
		Ta=150 deg C				
		VCB=50V, IE=0	<10	-	uA	
		VCB=60V, IE=0	-	<10	uA	
Emitter-Cut off Current	ICEX	VCE=60V, VBE=3V	-	<10	nA	
		VCE=10V, IB=0	<10	<10	nA	
Base-Cut off Current	IEBO	VEB=3V, IC=0	-	<10	nA	
Collector Emitter Saturation Voltage	VCE(Sat)*	IC=150mA, IB=15mA	<0.4	<0.3	V	
Base Emitter Saturation Voltage	VBE(Sat) *	IC=500mA, IB=50mA	<1.6	<1.0	V	
		IC=150mA, IB=15mA	<1.3	0.6-1.2	V	
		IC=500mA, IB=50mA	<2.6	<2.0	V	

**ELECTRICAL CHARACTERISTICS (Ta=25 deg C Unless Otherwise Specified)****PN2222, PN2222A**

DESCRIPTION	SYMBOL	TEST CONDITION	2222	2222A	UNIT	
<b>DC Current Gain</b>	hFE	IC=0.1mA, VCE=10V	>35	>35		
		IC=1mA, VCE=10V	>50	>50		
		IC=10mA, VCE=10V	>75	>75		
		IC=10mA, VCE=10V	-	>35		
		Ta=55 deg C				
		IC=150mA, VCE=10V	100-300	100-300		
		IC=150mA, VCE=1V	>50	>50		
		IC=500mA, VCE=10V	>30	>40		
<b>DYNAMIC CHARACTERISTICS</b>						
<b>Small Signal Current Gain</b>	hfe	ALL f=1kHz				
		IC=1mA, VCE=10V	-	50-300		
<b>Input Impedence</b>	hie	IC=10mA, VCE=10V	-	75-375		
		IC=1mA, VCE=10V	-	2.0-8.0	kohms	
<b>Voltage Feedback Ratio</b>	hre	IC=10mA, VCE=10V	-	0.25-1.25		
		IC=1mA, VCE=10V	-	8.0 x 10 <sup>-4</sup>		
<b>Out put Adimttance</b>	hoe	IC=10mA, VCE=10V	-	4.0		
		IC=1mA, VCE=10V	-	5.0-35	umhos	
<b>Collector Base Time Constant</b>	rb'Cc	IC=10mA, VCE=10V	-	25-200		
		IE=20mA, VCB=20V	-	<150	ps	
<b>Noise Figure</b>	NF	f=31.8MHz				
		IC=100uA, VCE=10V	-	<4.0	dB	
		Rs=1kohms, f=1kHz				
<b>DYNAMIC CHARACTERISTICS</b>						
<b>Transistors Frequency</b>	ft	IC=20mA, VCE=20V	>250	>300	MHz	
		f=100MHz				
<b>Out-Put Capacitance</b>	Cob	VCB=10V, IE=0	<8.0	<8.0	pF	
		f=1MHz				
<b>Input Capacitance</b>	Cib	VEB=0.5V, IC=0	<30	<25	pF	
		f=1MHz				
<b>SWITCHING Time</b>						
<b>Delay time</b>	td	IC=150mA, IB1=15mA		<10	ns	
<b>Rise time</b>	tr	VCC=30V, VBE=0.5V	-	<25	ns	
<b>Storage time</b>	ts	IC=150mA, IB1=		<225	ns	
<b>Fall time</b>	tf	IB2=15mA, VCC=30V	-	<60	ns	

\*Pulse Condition: Length =300us, Duty Cycle=2%

# TO-92 Plastic Package

## TO-92 Transistors on Tape and Ammo Pack

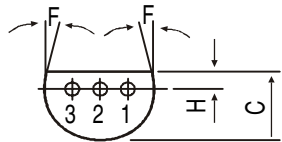
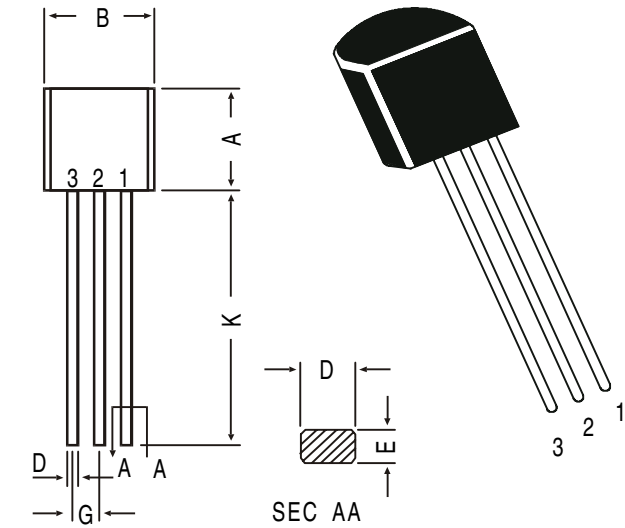

- PIN CONFIGURATION**
1. COLLECTOR
  2. BASE
  3. EMITTER

All dimensions in mm.

DIM	MIN.	MAX.
A	4.32	5.33
B	4.45	5.20
C	3.18	4.19
D	0.41	0.55
E	0.35	0.50
F	5 DEG	
G	1.14	1.40
H	1.14	1.53
K	12.70	—

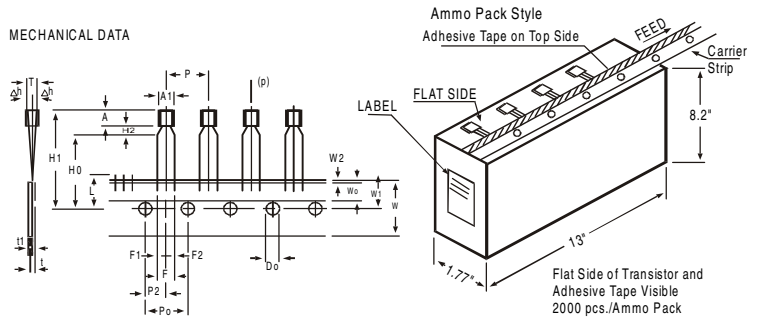

All dimensions in mm unless specified otherwise

ITEM	SYMBOL	SPECIFICATION				REMARKS
		MIN.	NOM.	MAX.	TOL.	
BODY WIDTH	A1	4.0		4.8		
BODY HEIGHT	A	4.8		5.2		
BODY THICKNESS	T	3.9		4.2		
PITCH OF COMPONENT	P		12.7		±1	
FEED HOLE PITCH	Po		12.7		±0.3	CUMULATIVE PITCH ERROR 1.0 mm/20 PITCH
FEED HOLE CENTRE TO COMPONENT CENTRE	P2		6.35		±0.4	TO BE MEASURED AT BOTTOM OF CLINCH
DISTANCE BETWEEN OUTER LEADS	F	5.08			+0.6 -0.2	
COMPONENT ALIGNMENT	Δh	0		1		AT TOP OF BODY
TAPE WIDTH	W	18			±0.5	
HOLD-DOWN TAPE WIDTH	W0	6			±0.2	
HOLE POSITION	W1	9			+0.7 -0.5	
HOLD-DOWN TAPE POSITION	W2	0.5			±0.2	
LEAD WIRE CLINCH HEIGHT	Ho	16			±0.5	
COMPONENT HEIGHT	H1			23.25		
LENGTH OF SNIPPED LEADS	L			11.0		
FEED HOLE DIAMETER	Do	4			±0.2	
TOTAL TAPE THICKNESS	t			1.2		±0.3 - 0.6
LEAD - TO - LEAD DISTANCE F1,	F2	2.54			+0.4 -0.1	
CLINCH HEIGHT	H2			3		
PULL - OUT FORCE	(P)	6N				

### NOTES

1. MAXIMUM ALIGNMENT DEVIATION BETWEEN LEADS NOT TO BE GREATER THAN 0.2 mm.
2. MAXIMUM NON-CUMULATIVE VARIATION BETWEEN TAPE FEED HOLES SHALL NOT EXCEED 1 mm IN 20 PITCHES.
3. HOLDDOWN TAPE NOT TO EXCEED BEYOND THE EDGE(S) OF CARRIER TAPE AND THERE SHALL BE NO EXPOSURE OF ADHESIVE.
4. NO MORE THAN 3 CONSECUTIVE MISSING COMPONENTS ARE PERMITTED.
5. A TAPE TRAILER, HAVING AT LEAST THREE FEED HOLES ARE REQUIRED AFTER THE LAST COMPONENT.
6. SPLICES SHALL NOT INTERFERE WITH THE SPROCKET FEED HOLES.

## Packing Detail

PACKAGE	STANDARD PACK		INNER CARTON BOX		OUTER CARTON BOX		
	Details	Net Weight/Qty	Size	Qty	Size	Qty	Gr Wt
TO-92 Bulk	1K/polybag	200 gm/1K pcs	3" x 7.5" x 7.5"	5.0K	17" x 15" x 13.5"	80.0K	23 kgs
TO-92 T&A	2K/ammo box	645 gm/2K pcs	12.5" x 8" x 1.8"	2.0K	17" x 15" x 13.5"	32.0K	12.5 kgs

## Customer Notes

### Disclaimer

The product information and the selection guides facilitate selection of the CDIL's Discrete Semiconductor Device(s) best suited for application in your product(s) as per your requirement. It is recommended that you completely review our Data Sheet(s) so as to confirm that the Device(s) meet functionality parameters for your application. The information furnished on the CDIL Web Site/CD are believed to be accurate and reliable. CDIL however, does not assume responsibility for inaccuracies or incomplete information. Furthermore, CDIL does not assume liability whatsoever, arising out of the application or use of any CDIL product; neither does it convey any license under its patent rights nor rights of others. These products are not designed for use in life saving/support appliances or systems. CDIL customers selling these products (either as individual Discrete Semiconductor Devices or incorporated in their end products), in any life saving/support appliances or systems or applications do so at their own risk and CDIL will not be responsible for any damages resulting from such sale(s).

CDIL strives for continuous improvement and reserves the right to change the specifications of its products without prior notice.



CDIL is a registered Trademark of

**Continental Device India Limited**

C-120 Naraina Industrial Area, New Delhi 110 028, India.

Telephone + 91-11-2579 6150, 5141 1112 Fax + 91-11-2579 5290, 5141 1119  
email@cdil.com www.cdilsemi.com