

HOLES(6) ARE DESIGNED FOR M3X4mm SELF-TAPPING SCREWS USE.

Four(4) M4X20mm PAN HEAD SCREWS.

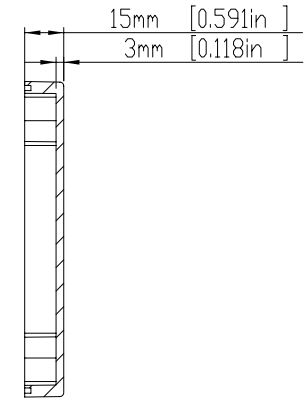

SECTION B-B

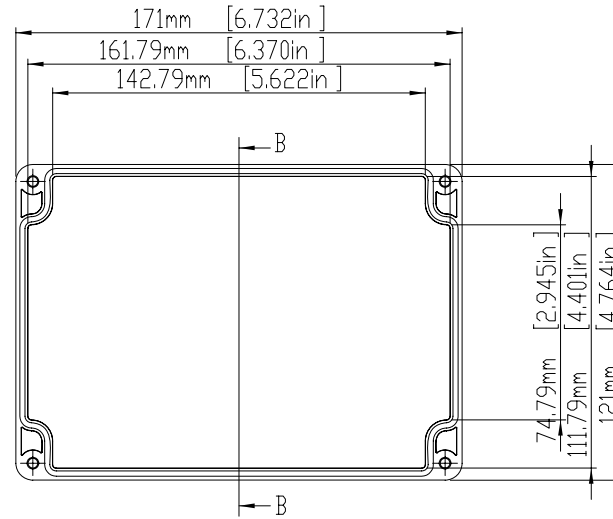
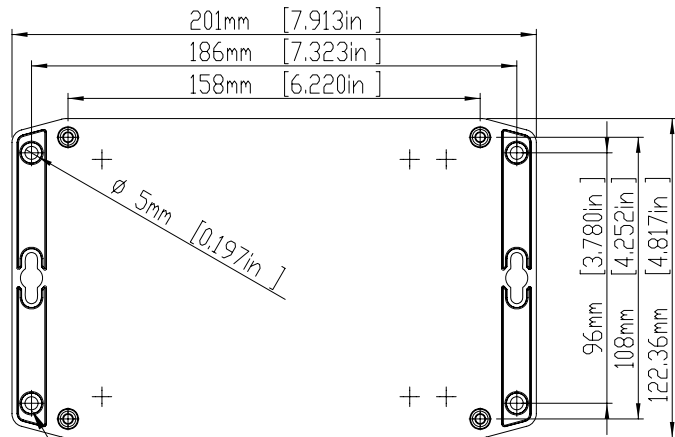

HOLES(4) ARE DESIGNED FOR M4 PAN HEAD MACHINE SCREWS USE.

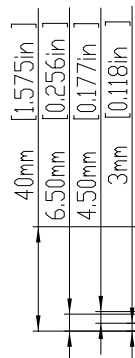
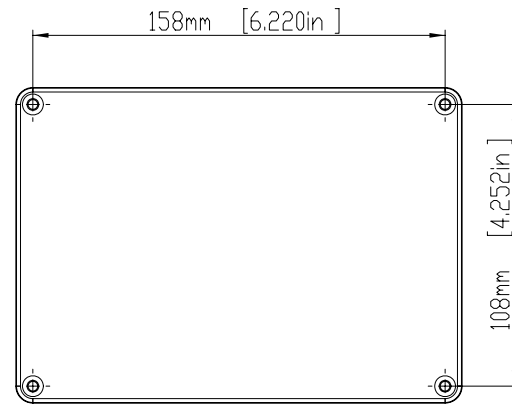

SECTION A-A

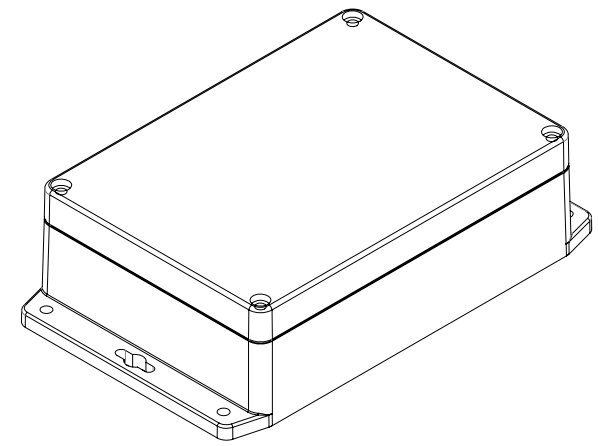
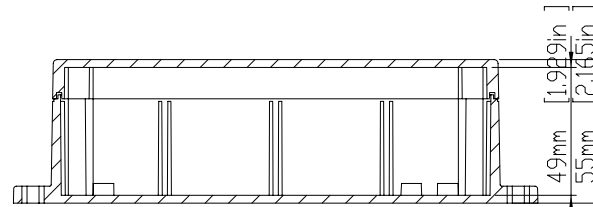

TOLERANCES: +/- 0.30 mm (+/- 0.012in)

宣又實業有限公司
GAINTA INDUSTRIES LTD.

繪圖 DRA'D BY
JACKY

日期 DATE
2010/11/8

材質 MATE.
PC ; ABS

圖名TITLE:
G214MF ; G313MF

圖號DWG NO:

版次REVISID:
A

STOCK NO.	MATERIAL	BASE-COLOR	COVER-COLOR
G214MF	POLYCARBONATE UL94-HB	LIGHT GRAY(RAL7035)	LIGHT GRAY(RAL7035)
G214CMF	POLYCARBONATE UL94-HB	LIGHT GRAY(RAL7035)	CLEAR
G313MF	ABS UL94-HB	DARK GRAY(RAL7000)	DARK GRAY(RAL7000)

宣又實業有限公司
GAINTA INDUSTRIES LTD.

繪圖 DRA'D BY
JACKY

日期 DATE
2010/11/30

材質 MATE.
PC;ABS

圖名TITLE:
G214MF ; G313MF

圖號DWG NO:

版次REVISID:

A