

## Very low drop voltage regulators with inhibit

### Features

- Very low dropout voltage (0.45 V)
- Very low quiescent current (typ. 50  $\mu$ A in OFF mode, 500  $\mu$ A in ON mode)
- Output current up to 500 mA
- Logic-controlled electronic shutdown
- Output voltages of 1.5; 1.8; 2.5; 3.3; 4.7; 5; 6; 8; 8.5; 9; 12 V
- Automotive Grade product: 1.8 V, 2.5 V, 3.3 V, 5.0 V, 8.0 V, 8.5 V  $V_{OUT}$  in DPAK and PPAK packages
- Internal current and thermal limit
- Only 2.2  $\mu$ F for stability
- Available in  $\pm 1\%$  (AB) or  $\pm 2\%$  (C) selection at 25  $^{\circ}$ C
- Supply voltage rejection: 80 db (typ.)
- Temperature range: -40 to 125  $^{\circ}$ C

### Description

The LFxxAB/LFxxC are very low drop regulators available in PENTAWATT, TO-220, TO-220FP, DPAK and PPAK package and in a wide range of output voltages.

The very low drop voltage (0.45 V) and the very low quiescent current make them particularly suitable for low noise, low power applications and specially in battery powered systems. In the 5 pins configuration (PENTAWATT and PPAK) a shutdown logic control function is available (pin 2, TTL compatible). This means that when the device is used as a local regulator, it is possible to

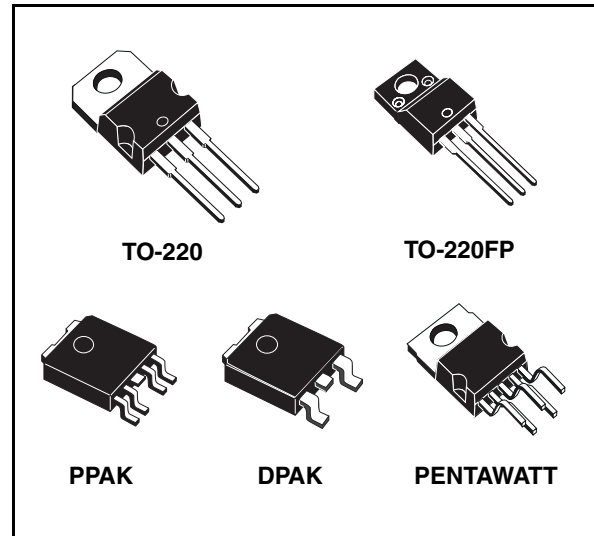

put a part of the board in standby, decreasing the total power consumption. In the three terminal configuration the device has the same electrical performance, but is fixed in the ON state. It requires only a 2.2  $\mu$ F capacitor for stability allowing space and cost saving. The LFxx is available as Automotive Grade in DPAK and PPAK packages, for the options of output voltages whose commercial Part Numbers are shown in the [Table 32](#) (order codes). These devices are qualified according to the specification AEC-Q100 of the Automotive market, in the temperature range -40  $^{\circ}$ C to 125  $^{\circ}$ C, and the statistical tests PAT, SYL, SBL are performed.

**Table 1. Device summary**

Part numbers						
LF15C	LF18AB	LF33C	LF50C	LF60AB	LF85C	LF90AB
LF15AB	LF25C	LF33AB	LF50AB	LF80C	LF85AB	LF120C
LF18C	LF25AB	LF47C	LF60C	LF80AB	LF90C	LF120AB

# Contents

1	Diagram .....	5
2	Pin configuration .....	6
3	Maximum ratings .....	7
4	Electrical characteristics .....	8
5	Typical performance characteristics .....	36
6	Package mechanical data .....	40
7	Order codes .....	47
8	Revision history .....	48

## List of figures

Figure 1.	Block diagram . . . . .	5
Figure 2.	Pin connections (top view) . . . . .	6
Figure 3.	Test circuit . . . . .	7
Figure 4.	Dropout voltage vs output current. . . . .	36
Figure 5.	Dropout voltage vs temperature . . . . .	36
Figure 6.	Supply current vs input voltage. . . . .	36
Figure 7.	Supply current vs input voltage. . . . .	36
Figure 8.	Short circuit current vs input voltage. . . . .	36
Figure 9.	Supply current vs temperature . . . . .	36
Figure 10.	Logic controlled precision 3.3/5.0 V selectable output . . . . .	37
Figure 11.	Sequential multi-output supply . . . . .	37
Figure 12.	Multiple supply with ON/OFF toggle switch . . . . .	38
Figure 13.	Basic inhibit functions . . . . .	38
Figure 14.	Delayed turn-on . . . . .	39
Figure 15.	Low voltage bulb blinker . . . . .	39

## List of tables

Table 1.	Device summary . . . . .	1
Table 2.	Absolute maximum ratings . . . . .	7
Table 3.	Thermal data . . . . .	7
Table 4.	Electrical characteristics for LF15AB . . . . .	8
Table 5.	Electrical characteristics for LF15C . . . . .	9
Table 6.	Electrical characteristics for LF18AB . . . . .	10
Table 7.	Electrical characteristics for LF18C . . . . .	11
Table 8.	Electrical characteristics for LF18CDT-TRY (Automotive Grade). . . . .	12
Table 9.	Electrical characteristics for LF25AB . . . . .	13
Table 10.	Electrical characteristics for LF25ABDT-TRY (Automotive Grade). . . . .	14
Table 11.	Electrical characteristics for LF25C . . . . .	15
Table 12.	Electrical characteristics for LF25CDT-TRY (Automotive Grade). . . . .	16
Table 13.	Electrical characteristics for LF33AB . . . . .	17
Table 14.	Electrical characteristics for LF33C . . . . .	18
Table 15.	Electrical characteristics for LF33CDT-TRY and LF33CPT-TRY (Automotive Grade). . . . .	19
Table 16.	Electrical characteristics for LF50AB . . . . .	20
Table 17.	Electrical characteristics for LF50ABDT-TRY (Automotive Grade). . . . .	21
Table 18.	Electrical characteristics for LF50C . . . . .	22
Table 19.	Electrical characteristics for LF50CDT-TRY and LF50CPT-TRY (Automotive Grade). . . . .	23
Table 20.	Electrical characteristics for LF60AB . . . . .	24
Table 21.	Electrical characteristics for LF60C . . . . .	25
Table 22.	Electrical characteristics for LF80AB . . . . .	26
Table 23.	Electrical characteristics for LF80C . . . . .	27
Table 24.	Electrical characteristics for LF80CDT-TRY (Automotive Grade). . . . .	28
Table 25.	Electrical characteristics for LF85AB . . . . .	29
Table 26.	Electrical characteristics for LF85C . . . . .	30
Table 27.	Electrical characteristics for LF85CDT-TRY and LF85CPT-TRY (Automotive Grade). . . . .	31
Table 28.	Electrical characteristics for LF90AB . . . . .	32
Table 29.	Electrical characteristics for LF90C . . . . .	33
Table 30.	Electrical characteristics for LF120AB . . . . .	34
Table 31.	Electrical characteristics for LF120C . . . . .	35
Table 32.	Order codes . . . . .	47
Table 33.	Document revision history . . . . .	48

# 1 Diagram

Figure 1. Block diagram

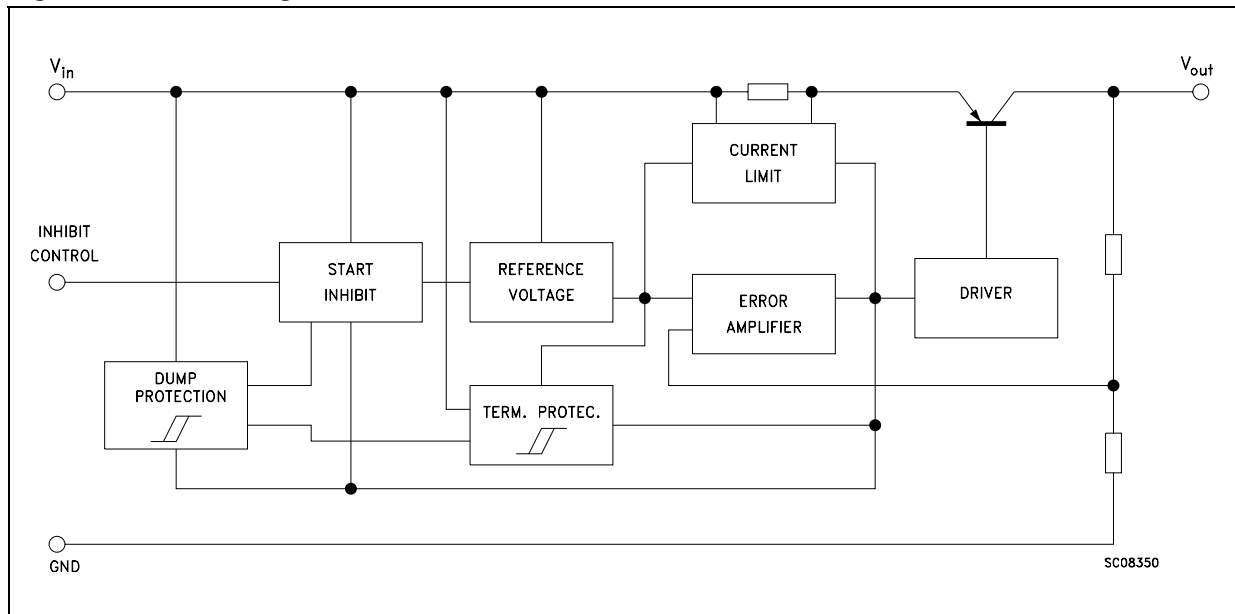

## 2 Pin configuration

Figure 2. Pin connections (top view)

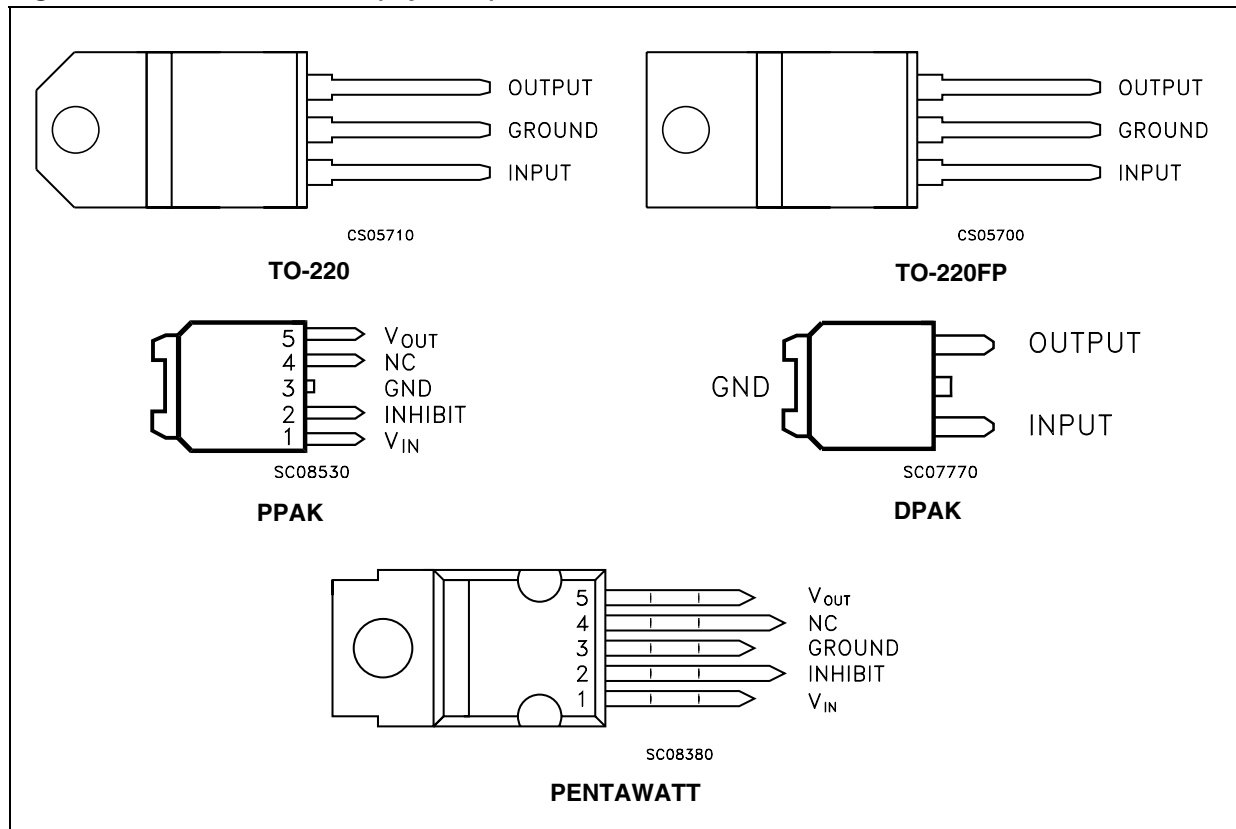

### 3 Maximum ratings

**Table 2. Absolute maximum ratings**

Symbol	Parameter	Value	Unit
$V_I$	DC input voltage	-0.5 to 40 <sup>(1)</sup>	V
$I_O$	Output current	Internally Limited	
$P_{TOT}$	Power dissipation	Internally Limited	
$T_{STG}$	Storage temperature range	-40 to 150	°C
$T_{OP}$	Operating junction temperature range	-40 to 125	°C

1. For  $18 < V_I < 40$  the regulator is in shut-down

**Table 3. Thermal data**

Symbol	Parameter	PENTAWATT	TO-220	TO-220FP	DPAK/PPAK	Unit
$R_{thJC}$	Thermal resistance junction-case	3	3	5	8	°C/W
$R_{thJA}$	Thermal resistance junction-ambient	50	50	60	100	°C/W

**Figure 3. Test circuit**

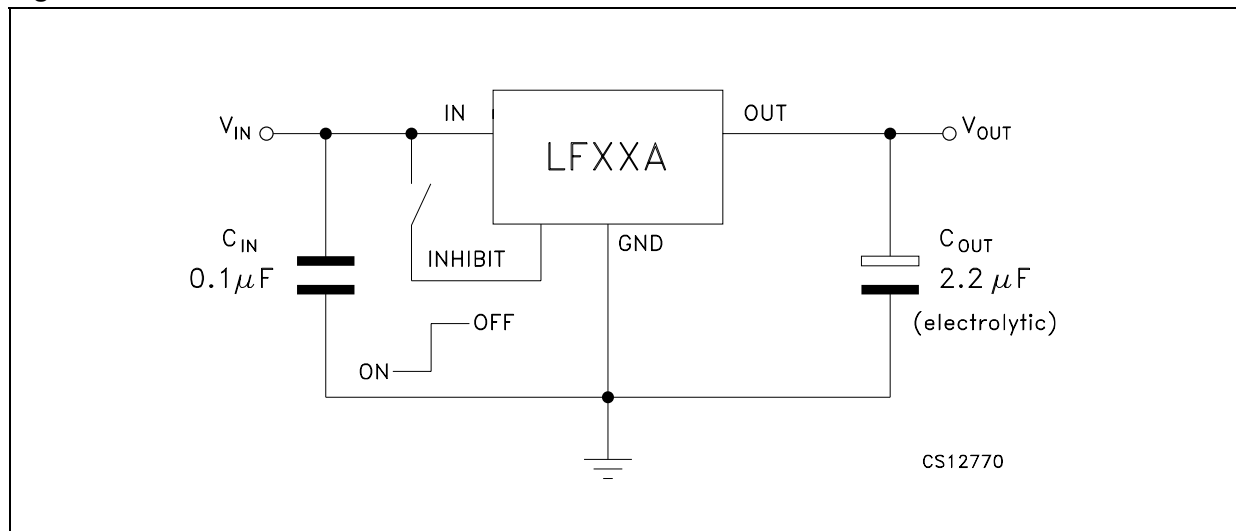

## 4 Electrical characteristics

**Table 4. Electrical characteristics for LF15AB** (refer to the test circuits,  $T_J = 25\text{ }^\circ\text{C}$ ,  $C_I = 0.1\text{ }\mu\text{F}$ ,  $C_O = 2.2\text{ }\mu\text{F}$  unless otherwise specified.)

Symbol	Parameter	Test conditions	Min.	Typ.	Max.	Unit	
$V_O$	Output voltage	$I_O = 50\text{ mA}$ , $V_I = 3.5\text{ V}$	1.485	1.5	1.515	V	
		$I_O = 50\text{ mA}$ , $V_I = 3.5\text{ V}$ , $T_a = -25\text{ to }85\text{ }^\circ\text{C}$	1.470		1.530		
$V_I$	Operating input voltage	$I_O = 500\text{ mA}$	2.5		16	V	
$I_O$	Output current limit			1		A	
$\Delta V_O$	Line regulation	$V_I = 2.5\text{ to }16\text{ V}$ , $I_O = 5\text{ mA}$		2	10	mV	
$\Delta V_O$	Load regulation	$V_I = 2.8\text{ V}$ , $I_O = 5\text{ to }500\text{ mA}$		2	10	mV	
$I_d$	Quiescent current	$V_I = 2.5\text{ to }16\text{ V}$ , $I_O = 0\text{ mA}$	ON MODE		0.5	1	mA
		$V_I = 2.8\text{ to }16\text{ V}$ , $I_O = 500\text{ mA}$				12	
		$V_I = 6\text{ V}$	OFF MODE		50	100	$\mu\text{A}$
SVR	Supply voltage rejection	$I_O = 5\text{ mA}$ , $V_I = 3.5 \pm 1\text{ V}$	$f = 120\text{ Hz}$		82	dB	
			$f = 1\text{ kHz}$		77		
			$f = 10\text{ kHz}$		65		
eN	Output noise voltage	$B = 10\text{ Hz to }100\text{ kHz}$		50		$\mu\text{V}$	
$V_d$	Dropout voltage	$I_O = 200\text{ mA}$		1		V	
$V_{IL}$	Control input logic low	$T_a = -40\text{ to }125\text{ }^\circ\text{C}$			0.8	V	
$V_{IH}$	Control input logic high	$T_a = -40\text{ to }125\text{ }^\circ\text{C}$	2			V	
$I_I$	Control input current	$V_I = 6\text{ V}$ , $V_C = 6\text{ V}$		10		$\mu\text{A}$	
$C_O$	Output bypass capacitance	$\text{ESR} = 0.1\text{ to }10\text{ }\Omega$ , $I_O = 0\text{ to }500\text{ mA}$	2	10		$\mu\text{F}$	



**Table 5. Electrical characteristics for LF15C** (refer to the test circuits,  $T_J = 25\text{ }^\circ\text{C}$ ,  $C_I = 0.1\text{ }\mu\text{F}$ ,  $C_O = 2.2\text{ }\mu\text{F}$  unless otherwise specified.)

Symbol	Parameter	Test conditions	Min.	Typ.	Max.	Unit
$V_O$	Output voltage	$I_O = 50\text{ mA}$ , $V_I = 3.5\text{ V}$	1.47	1.5	1.53	V
		$I_O = 50\text{ mA}$ , $V_I = 3.5\text{ V}$ , $T_a = -25\text{ to }85\text{ }^\circ\text{C}$	1.44		1.56	
$V_I$	Operating input voltage	$I_O = 500\text{ mA}$	2.5		16	V
$I_O$	Output current limit			1		A
$\Delta V_O$	Line regulation	$V_I = 2.5\text{ to }16\text{ V}$ , $I_O = 5\text{ mA}$		2	10	mV
$\Delta V_O$	Load regulation	$V_I = 2.8\text{ V}$ , $I_O = 5\text{ to }500\text{ mA}$		2	10	mV
$I_d$	Quiescent current	$V_I = 2.5\text{ to }16\text{ V}$ , $I_O = 0\text{ mA}$	ON MODE	0.5	1	mA
		$V_I = 2.8\text{ to }16\text{ V}$ , $I_O = 500\text{ mA}$				
		$V_I = 6\text{ V}$	OFF MODE	50	100	$\mu\text{A}$
SVR	Supply voltage rejection	$I_O = 5\text{ mA}$ , $V_I = 3.5 \pm 1\text{ V}$	$f = 120\text{ Hz}$	82		dB
			$f = 1\text{ kHz}$	77		
			$f = 10\text{ kHz}$	65		
eN	Output noise voltage	$B = 10\text{ Hz to }100\text{ kHz}$		50		$\mu\text{V}$
$V_d$	Dropout voltage	$I_O = 200\text{ mA}$		1		V
$V_{IL}$	Control input logic low	$T_a = -40\text{ to }125\text{ }^\circ\text{C}$			0.8	V
$V_{IH}$	Control input logic high	$T_a = -40\text{ to }125\text{ }^\circ\text{C}$	2			V
$I_I$	Control input current	$V_I = 6\text{ V}$ , $V_C = 6\text{ V}$		10		$\mu\text{A}$
$C_O$	Output bypass capacitance	$\text{ESR} = 0.1\text{ to }10\text{ }\Omega$ , $I_O = 0\text{ to }500\text{ mA}$	2	10		$\mu\text{F}$

**Table 6. Electrical characteristics for LF18AB** (refer to the test circuits,  $T_J = 25\text{ }^\circ\text{C}$ ,  $C_1 = 0.1\text{ }\mu\text{F}$ ,  $C_O = 2.2\text{ }\mu\text{F}$  unless otherwise specified.)

Symbol	Parameter	Test conditions	Min.	Typ.	Max.	Unit
$V_O$	Output voltage	$I_O = 50\text{ mA}$ , $V_I = 3.3\text{ V}$	1.782	1.8	1.818	V
		$I_O = 50\text{ mA}$ , $V_I = 3.3\text{ V}$ , $T_a = -25\text{ to }85\text{ }^\circ\text{C}$	1.764		1.836	
$V_I$	Operating input voltage	$I_O = 500\text{ mA}$	3		16	V
$I_O$	Output current limit			1		A
$\Delta V_O$	Line regulation	$V_I = 2.8\text{ to }16\text{ V}$ , $I_O = 5\text{ mA}$		2	12	mV
$\Delta V_O$	Load regulation	$V_I = 3.3\text{ V}$ , $I_O = 5\text{ to }500\text{ mA}$		2	10	mV
$I_d$	Quiescent current	$V_I = 2.5\text{ to }16\text{ V}$ , $I_O = 0\text{ mA}$	ON MODE	0.5	1	mA
		$V_I = 3.1\text{ to }16\text{ V}$ , $I_O = 500\text{ mA}$				
		$V_I = 6\text{ V}$	OFF MODE	50	100	$\mu\text{A}$
SVR	Supply voltage rejection	$I_O = 5\text{ mA}$ , $V_I = 3.5 \pm 1\text{ V}$	$f = 120\text{ Hz}$	82		dB
			$f = 1\text{ kHz}$	77		
			$f = 10\text{ kHz}$	60		
eN	Output noise voltage	$B = 10\text{ Hz to }100\text{ kHz}$		50		$\mu\text{V}$
$V_d$	Dropout voltage	$I_O = 200\text{ mA}$		0.7		V
$V_{IL}$	Control input logic low	$T_a = -40\text{ to }125\text{ }^\circ\text{C}$			0.8	V
$V_{IH}$	Control input logic high	$T_a = -40\text{ to }125\text{ }^\circ\text{C}$	2			V
$I_I$	Control input current	$V_I = 6\text{ V}$ , $V_C = 6\text{ V}$		10		$\mu\text{A}$
$C_O$	Output bypass capacitance	$\text{ESR} = 0.1\text{ to }10\text{ }\Omega$ , $I_O = 0\text{ to }500\text{ mA}$	2	10		$\mu\text{F}$

**Table 7. Electrical characteristics for LF18C** (refer to the test circuits,  $T_J = 25\text{ °C}$ ,  $C_I = 0.1\text{ }\mu\text{F}$ ,  $C_O = 2.2\text{ }\mu\text{F}$  unless otherwise specified.)

Symbol	Parameter	Test conditions	Min.	Typ.	Max.	Unit	
$V_O$	Output voltage	$I_O = 50\text{ mA}$ , $V_I = 3.5\text{ V}$	1.764	1.8	1.836	V	
		$I_O = 50\text{ mA}$ , $V_I = 3.5\text{ V}$ , $T_a = -25\text{ to }85\text{ °C}$	1.728		1.872		
$V_I$	Operating input voltage	$I_O = 500\text{ mA}$	3		16	V	
$I_O$	Output current limit			1		A	
$\Delta V_O$	Line regulation	$V_I = 2.8\text{ to }16\text{ V}$ , $I_O = 5\text{ mA}$		2	12	mV	
$\Delta V_O$	Load regulation	$V_I = 3.3\text{ V}$ , $I_O = 5\text{ to }500\text{ mA}$		2	10	mV	
$I_d$	Quiescent current	$V_I = 2.5\text{ to }16\text{ V}$ , $I_O = 0\text{ mA}$	ON MODE		0.5	1	mA
		$V_I = 3.1\text{ to }16\text{ V}$ , $I_O = 500\text{ mA}$				12	
		$V_I = 6\text{ V}$	OFF MODE		50	100	$\mu\text{A}$
SVR	Supply voltage rejection	$I_O = 5\text{ mA}$ , $V_I = 3.5 \pm 1\text{ V}$	$f = 120\text{ Hz}$		82	dB	
			$f = 1\text{ kHz}$		77		
			$f = 10\text{ kHz}$		60		
eN	Output noise voltage	$B = 10\text{ Hz to }100\text{ kHz}$		50		$\mu\text{V}$	
$V_d$	Dropout voltage	$I_O = 200\text{ mA}$		0.7		V	
$V_{IL}$	Control input logic low	$T_a = -40\text{ to }125\text{ °C}$			0.8	V	
$V_{IH}$	Control input logic high	$T_a = -40\text{ to }125\text{ °C}$	2			V	
$I_I$	Control input current	$V_I = 6\text{ V}$ , $V_C = 6\text{ V}$		10		$\mu\text{A}$	
$C_O$	Output bypass capacitance	$\text{ESR} = 0.1\text{ to }10\text{ }\Omega$ , $I_O = 0\text{ to }500\text{ mA}$	2	10		$\mu\text{F}$	

**Table 8. Electrical characteristics for LF18CDT-TRY (Automotive Grade)** (refer to the test circuits,  $T_A = -40$  to  $125^\circ\text{C}$ ,  $C_I = 0.1 \mu\text{F}$ ,  $C_O = 2.2 \mu\text{F}$  unless otherwise specified.)

Symbol	Parameter	Test conditions	Min.	Typ.	Max.	Unit	
$V_O$	Output voltage	$I_O = 50 \text{ mA}$ , $V_I = 3.5 \text{ V}$ , $T_a = 25^\circ\text{C}$	1.764	1.8	1.836	V	
		$I_O = 50 \text{ mA}$ , $V_I = 3.5 \text{ V}$	1.713		1.887		
$V_I$	Operating input voltage	$I_O = 500 \text{ mA}$	3		16	V	
$I_O$	Output current limit	$T_a = 25^\circ\text{C}$		1		A	
$\Delta V_O$	Line regulation	$V_I = 2.8$ to $16 \text{ V}$ , $I_O = 5 \text{ mA}$		2	15	mV	
$\Delta V_O$	Load regulation	$V_I = 3.3 \text{ V}$ , $I_O = 5$ to $500 \text{ mA}$		2	15	mV	
$I_d$	Quiescent current	$V_I = 2.5$ to $16 \text{ V}$ , $I_O = 0 \text{ mA}$	ON MODE		0.5	2	mA
		$V_I = 3.1$ to $16 \text{ V}$ , $I_O = 500 \text{ mA}$			12		
		$V_I = 6 \text{ V}$	OFF MODE		50	120	$\mu\text{A}$
SVR	Supply voltage rejection	$I_O = 5 \text{ mA}$ , $V_I = 3.5 \pm 1 \text{ V}$ $T_a = 25^\circ\text{C}$	$f = 120 \text{ Hz}$		82	dB	
			$f = 1 \text{ kHz}$		77		
			$f = 10 \text{ kHz}$		60		
eN	Output noise voltage	$B = 10 \text{ Hz}$ to $100 \text{ kHz}$ , $T_a = 25^\circ\text{C}$		50		$\mu\text{V}$	
$V_d$	Dropout voltage	$I_O = 200 \text{ mA}$		0.2	1.3	V	
		$I_O = 500 \text{ mA}$		0.4	1.3		
$V_{IL}$	Control input logic low				0.8	V	
$V_{IH}$	Control input logic high		2			V	
$I_I$	Control input current	$V_I = 6 \text{ V}$ , $V_C = 6 \text{ V}$ , $T_a = 25^\circ\text{C}$		10		$\mu\text{A}$	
$C_O$	Output bypass capacitance	$\text{ESR} = 0.1$ to $10 \Omega$ , $I_O = 0$ to $500 \text{ mA}$	2	10		$\mu\text{F}$	

**Table 9. Electrical characteristics for LF25AB** (refer to the test circuits,  $T_J = 25\text{ }^\circ\text{C}$ ,  $C_1 = 0.1\text{ }\mu\text{F}$ ,  $C_O = 2.2\text{ }\mu\text{F}$  unless otherwise specified.)

Symbol	Parameter	Test conditions	Min.	Typ.	Max.	Unit
$V_O$	Output voltage	$I_O = 50\text{ mA}$ , $V_I = 4.5\text{ V}$	2.475	2.5	2.525	V
		$I_O = 50\text{ mA}$ , $V_I = 4.5\text{ V}$ , $T_a = -25\text{ to }85\text{ }^\circ\text{C}$	2.450		2.550	
$V_I$	Operating input voltage	$I_O = 500\text{ mA}$			16	V
$I_O$	Output current limit			1		A
$\Delta V_O$	Line regulation	$V_I = 3.5\text{ to }16\text{ V}$ , $I_O = 5\text{ mA}$		2	12	mV
$\Delta V_O$	Load regulation	$V_I = 3.8\text{ V}$ , $I_O = 5\text{ to }500\text{ mA}$		2	12	mV
$I_d$	Quiescent current	$V_I = 3.5\text{ to }16\text{ V}$ , $I_O = 0\text{ mA}$	ON MODE	0.5	1	mA
		$V_I = 3.8\text{ to }16\text{ V}$ , $I_O = 500\text{ mA}$				
		$V_I = 6\text{ V}$	OFF MODE	50	100	$\mu\text{A}$
SVR	Supply voltage rejection	$I_O = 5\text{ mA}$ , $V_I = 4.5 \pm 1\text{ V}$	$f = 120\text{ Hz}$	82		dB
			$f = 1\text{ kHz}$	77		
			$f = 10\text{ kHz}$	65		
eN	Output noise voltage	$B = 10\text{ Hz to }100\text{ kHz}$		50		$\mu\text{V}$
$V_d$	Dropout voltage	$I_O = 200\text{ mA}$		0.2	0.35	V
		$I_O = 500\text{ mA}$		0.4	0.7	
$V_{IL}$	Control input logic low	$T_a = -40\text{ to }125\text{ }^\circ\text{C}$			0.8	V
$V_{IH}$	Control input logic high	$T_a = -40\text{ to }125\text{ }^\circ\text{C}$	2			V
$I_I$	Control input current	$V_I = 6\text{ V}$ , $V_C = 6\text{ V}$		10		$\mu\text{A}$
$C_O$	Output bypass capacitance	$\text{ESR} = 0.1\text{ to }10\text{ }\Omega$ , $I_O = 0\text{ to }500\text{ mA}$	2	10		$\mu\text{F}$

**Table 10. Electrical characteristics for LF25ABDT-TRY (Automotive Grade)** (refer to the test circuits,  $T_A = -40$  to  $125^\circ\text{C}$ ,  $C_I = 0.1 \mu\text{F}$ ,  $C_O = 2.2 \mu\text{F}$  unless otherwise specified.)

Symbol	Parameter	Test conditions	Min.	Typ.	Max.	Unit
$V_O$	Output voltage	$I_O = 50 \text{ mA}$ , $V_I = 4.5 \text{ V}$ , $T_a = 25^\circ\text{C}$	2.475	2.5	2.525	V
		$I_O = 50 \text{ mA}$ , $V_I = 4.5 \text{ V}$	2.435		2.565	
$V_I$	Operating input voltage	$I_O = 500 \text{ mA}$			16	V
$I_O$	Output current limit	$T_a = 25^\circ\text{C}$		1		A
$\Delta V_O$	Line regulation	$V_I = 3.5$ to $16 \text{ V}$ , $I_O = 5 \text{ mA}$		2	15	mV
$\Delta V_O$	Load regulation	$V_I = 3.8 \text{ V}$ , $I_O = 5$ to $500 \text{ mA}$		2	15	mV
$I_d$	Quiescent current	$V_I = 3.5$ to $16 \text{ V}$ , $I_O = 0 \text{ mA}$	ON MODE	0.5	2	mA
		$V_I = 3.8$ to $16 \text{ V}$ , $I_O = 500 \text{ mA}$				
		$V_I = 6 \text{ V}$	OFF MODE	50	120	$\mu\text{A}$
SVR	Supply voltage rejection	$I_O = 5 \text{ mA}$ , $V_I = 4.5 \pm 1 \text{ V}$ $T_a = 25^\circ\text{C}$	$f = 120 \text{ Hz}$	82		dB
			$f = 1 \text{ kHz}$	77		
			$f = 10 \text{ kHz}$	65		
eN	Output noise voltage	$B = 10 \text{ Hz}$ to $100 \text{ kHz}$ , $T_a = 25^\circ\text{C}$		50		$\mu\text{V}$
$V_d$	Dropout voltage	$I_O = 200 \text{ mA}$		0.2	1.3	V
		$I_O = 500 \text{ mA}$		0.4	1.3	
$V_{IL}$	Control input logic low				0.8	V
$V_{IH}$	Control input logic high		2			V
$I_I$	Control input current	$V_I = 6 \text{ V}$ , $V_C = 6 \text{ V}$ , $T_a = 25^\circ\text{C}$		10		$\mu\text{A}$
$C_O$	Output bypass capacitance	$\text{ESR} = 0.1$ to $10 \Omega$ , $I_O = 0$ to $500 \text{ mA}$	2	10		$\mu\text{F}$

**Table 11. Electrical characteristics for LF25C** (refer to the test circuits,  $T_J = 25\text{ }^\circ\text{C}$ ,  $C_I = 0.1\text{ }\mu\text{F}$ ,  $C_O = 2.2\text{ }\mu\text{F}$  unless otherwise specified.)

Symbol	Parameter	Test conditions	Min.	Typ.	Max.	Unit
$V_O$	Output voltage	$I_O = 50\text{ mA}$ , $V_I = 4.5\text{ V}$	2.45	2.5	2.55	V
		$I_O = 50\text{ mA}$ , $V_I = 4.5\text{ V}$ , $T_a = -25\text{ to }85\text{ }^\circ\text{C}$	2.4		2.6	
$V_I$	Operating input voltage	$I_O = 500\text{ mA}$			16	V
$I_O$	Output current limit			1		A
$\Delta V_O$	Line regulation	$V_I = 3.5\text{ to }16\text{ V}$ , $I_O = 5\text{ mA}$		2	12	mV
$\Delta V_O$	Load regulation	$V_I = 3.8\text{ V}$ , $I_O = 5\text{ to }500\text{ mA}$		2	12	mV
$I_d$	Quiescent current	$V_I = 3.5\text{ to }16\text{ V}$ , $I_O = 0\text{ mA}$	ON MODE	0.5	1	mA
		$V_I = 3.8\text{ to }16\text{ V}$ , $I_O = 500\text{ mA}$				
		$V_I = 6\text{ V}$	OFF MODE	50	100	$\mu\text{A}$
SVR	Supply voltage rejection	$I_O = 5\text{ mA}$ , $V_I = 4.5 \pm 1\text{ V}$	$f = 120\text{ Hz}$	82		dB
			$f = 1\text{ kHz}$	77		
			$f = 10\text{ kHz}$	65		
eN	Output noise voltage	$B = 10\text{ Hz to }100\text{ kHz}$		50		$\mu\text{V}$
$V_d$	Dropout voltage	$I_O = 200\text{ mA}$		0.2	0.35	V
		$I_O = 500\text{ mA}$		0.4	0.7	
$V_{IL}$	Control input logic low	$T_a = -40\text{ to }125\text{ }^\circ\text{C}$			0.8	V
$V_{IH}$	Control input logic high	$T_a = -40\text{ to }125\text{ }^\circ\text{C}$	2			V
$I_I$	Control input current	$V_I = 6\text{ V}$ , $V_C = 6\text{ V}$		10		$\mu\text{A}$
$C_O$	Output bypass capacitance	$\text{ESR} = 0.1\text{ to }10\text{ }\Omega$ , $I_O = 0\text{ to }500\text{ mA}$	2	10		$\mu\text{F}$

**Table 12. Electrical characteristics for LF25CDT-TRY (Automotive Grade)** (refer to the test circuits,  $T_A = -40$  to  $125^\circ\text{C}$ ,  $C_I = 0.1 \mu\text{F}$ ,  $C_O = 2.2 \mu\text{F}$  unless otherwise specified.)

Symbol	Parameter	Test conditions	Min.	Typ.	Max.	Unit
$V_O$	Output voltage	$I_O = 50 \text{ mA}$ , $V_I = 4.5 \text{ V}$ , $T_a = 25^\circ\text{C}$	2.45	2.5	2.55	V
		$I_O = 50 \text{ mA}$ , $V_I = 4.5 \text{ V}$	2.385		2.615	
$V_I$	Operating input voltage	$I_O = 500 \text{ mA}$			16	V
$I_O$	Output current limit	$T_a = 25^\circ\text{C}$		1		A
$\Delta V_O$	Line regulation	$V_I = 3.5$ to $16 \text{ V}$ , $I_O = 5 \text{ mA}$		2	15	mV
$\Delta V_O$	Load regulation	$V_I = 3.8 \text{ V}$ , $I_O = 5$ to $500 \text{ mA}$		2	15	mV
$I_d$	Quiescent current	$V_I = 3.5$ to $16 \text{ V}$ , $I_O = 0 \text{ mA}$	ON MODE	0.5	2	mA
		$V_I = 3.8$ to $16 \text{ V}$ , $I_O = 500 \text{ mA}$				
		$V_I = 6 \text{ V}$	OFF MODE	50	120	$\mu\text{A}$
SVR	Supply voltage rejection	$I_O = 5 \text{ mA}$ , $V_I = 4.5 \pm 1 \text{ V}$ $T_a = 25^\circ\text{C}$	$f = 120 \text{ Hz}$	82		dB
			$f = 1 \text{ kHz}$	77		
			$f = 10 \text{ kHz}$	65		
eN	Output noise voltage	$B = 10 \text{ Hz}$ to $100 \text{ kHz}$ , $T_a = 25^\circ\text{C}$		50		$\mu\text{V}$
$V_d$	Dropout voltage	$I_O = 200 \text{ mA}$		0.2	1.3	V
		$I_O = 500 \text{ mA}$		0.4	1.3	
$V_{IL}$	Control input logic low				0.8	V
$V_{IH}$	Control input logic high		2			V
$I_I$	Control input current	$V_I = 6 \text{ V}$ , $V_C = 6 \text{ V}$ , $T_a = 25^\circ\text{C}$		10		$\mu\text{A}$
$C_O$	Output bypass capacitance	$\text{ESR} = 0.1$ to $10 \Omega$ , $I_O = 0$ to $500 \text{ mA}$	2	10		$\mu\text{F}$



**Table 13. Electrical characteristics for LF33AB** (refer to the test circuits,  $T_J = 25\text{ }^\circ\text{C}$ ,  $C_1 = 0.1\text{ }\mu\text{F}$ ,  $C_O = 2.2\text{ }\mu\text{F}$  unless otherwise specified.)

Symbol	Parameter	Test conditions	Min.	Typ.	Max.	Unit	
$V_O$	Output voltage	$I_O = 50\text{ mA}$ , $V_I = 5.3\text{ V}$	3.267	3.3	3.333	V	
		$I_O = 50\text{ mA}$ , $V_I = 5.3\text{ V}$ , $T_a = -25\text{ to }85\text{ }^\circ\text{C}$	3.234		3.366		
$V_I$	Operating input voltage	$I_O = 500\text{ mA}$			16	V	
$I_O$	Output current limit			1		A	
$\Delta V_O$	Line regulation	$V_I = 4.3\text{ to }16\text{ V}$ , $I_O = 5\text{ mA}$		3	16	mV	
$\Delta V_O$	Load regulation	$V_I = 4.6\text{ V}$ , $I_O = 5\text{ to }500\text{ mA}$		3	16	mV	
$I_d$	Quiescent current	$V_I = 4.3\text{ to }16\text{ V}$ , $I_O = 0\text{ mA}$	ON MODE		0.5	1	mA
		$V_I = 4.6\text{ to }16\text{ V}$ , $I_O = 500\text{ mA}$				12	
		$V_I = 6\text{ V}$	OFF MODE		50	100	$\mu\text{A}$
SVR	Supply voltage rejection	$I_O = 5\text{ mA}$ , $V_I = 5.3 \pm 1\text{ V}$	$f = 120\text{ Hz}$		80	dB	
			$f = 1\text{ kHz}$		75		
			$f = 10\text{ kHz}$		65		
eN	Output noise voltage	$B = 10\text{ Hz to }100\text{ kHz}$		50		$\mu\text{V}$	
$V_d$	Dropout voltage	$I_O = 200\text{ mA}$		0.2	0.35	V	
		$I_O = 500\text{ mA}$		0.4	0.7		
$V_{IL}$	Control input logic low	$T_a = -40\text{ to }125\text{ }^\circ\text{C}$			0.8	V	
$V_{IH}$	Control input logic high	$T_a = -40\text{ to }125\text{ }^\circ\text{C}$	2			V	
$I_I$	Control input current	$V_I = 6\text{ V}$ , $V_C = 6\text{ V}$		10		$\mu\text{A}$	
$C_O$	Output bypass capacitance	$\text{ESR} = 0.1\text{ to }10\text{ }\Omega$ , $I_O = 0\text{ to }500\text{ mA}$	2	10		$\mu\text{F}$	

**Table 14. Electrical characteristics for LF33C** (refer to the test circuits,  $T_J = 25\text{ }^\circ\text{C}$ ,  $C_I = 0.1\text{ }\mu\text{F}$ ,  $C_O = 2.2\text{ }\mu\text{F}$  unless otherwise specified.)

Symbol	Parameter	Test conditions	Min.	Typ.	Max.	Unit	
$V_O$	Output voltage	$I_O = 50\text{ mA}$ , $V_I = 5.3\text{ V}$	3.234	3.3	3.366	V	
		$I_O = 50\text{ mA}$ , $V_I = 5.3\text{ V}$ , $T_a = -25\text{ to }85\text{ }^\circ\text{C}$	3.168		3.432		
$V_I$	Operating input voltage	$I_O = 500\text{ mA}$			16	V	
$I_O$	Output current limit			1		A	
$\Delta V_O$	Line regulation	$V_I = 4.3\text{ to }16\text{ V}$ , $I_O = 5\text{ mA}$		3	16	mV	
$\Delta V_O$	Load regulation	$V_I = 4.6\text{ V}$ , $I_O = 5\text{ to }500\text{ mA}$		3	16	mV	
$I_d$	Quiescent current	$V_I = 4.3\text{ to }16\text{ V}$ , $I_O = 0\text{ mA}$	ON MODE		0.5	1	mA
		$V_I = 4.6\text{ to }16\text{ V}$ , $I_O = 500\text{ mA}$				12	
		$V_I = 6\text{ V}$	OFF MODE		50	100	$\mu\text{A}$
SVR	Supply voltage rejection	$I_O = 5\text{ mA}$ , $V_I = 5.3 \pm 1\text{ V}$	$f = 120\text{ Hz}$		80	dB	
			$f = 1\text{ kHz}$		75		
			$f = 10\text{ kHz}$		65		
eN	Output noise voltage	$B = 10\text{ Hz to }100\text{ kHz}$		50		$\mu\text{V}$	
$V_d$	Dropout voltage	$I_O = 200\text{ mA}$		0.2	0.35	V	
		$I_O = 500\text{ mA}$		0.4	0.7		
$V_{IL}$	Control input logic low	$T_a = -40\text{ to }125\text{ }^\circ\text{C}$			0.8	V	
$V_{IH}$	Control input logic high	$T_a = -40\text{ to }125\text{ }^\circ\text{C}$	2			V	
$I_I$	Control input current	$V_I = 6\text{ V}$ , $V_C = 6\text{ V}$		10		$\mu\text{A}$	
$C_O$	Output bypass capacitance	$\text{ESR} = 0.1\text{ to }10\text{ }\Omega$ , $I_O = 0\text{ to }500\text{ mA}$	2	10		$\mu\text{F}$	

**Table 15. Electrical characteristics for LF33CDT-TRY and LF33CPT-TRY (Automotive Grade)**  
(refer to the test circuits,  $T_A = -40$  to  $125^\circ\text{C}$ ,  $C_I = 0.1 \mu\text{F}$ ,  $C_O = 2.2 \mu\text{F}$  unless otherwise specified.)

Symbol	Parameter	Test conditions	Min.	Typ.	Max.	Unit
$V_O$	Output voltage	$I_O = 50 \text{ mA}$ , $V_I = 5.3 \text{ V}$ , $T_a = 25^\circ\text{C}$	3.234	3.3	3.366	V
		$I_O = 50 \text{ mA}$ , $V_I = 5.3 \text{ V}$ ,	3.153		3.447	
$V_I$	Operating input voltage	$I_O = 500 \text{ mA}$			16	V
$I_O$	Output current limit	$T_a = 25^\circ\text{C}$		1		A
$\Delta V_O$	Line regulation	$V_I = 4.3$ to $16 \text{ V}$ , $I_O = 5 \text{ mA}$		3	19	mV
$\Delta V_O$	Load regulation	$V_I = 4.6 \text{ V}$ , $I_O = 5$ to $500 \text{ mA}$		3	19	mV
$I_d$	Quiescent current	$V_I = 4.3$ to $16 \text{ V}$ , $I_O = 0 \text{ mA}$	ON MODE	0.5	2	mA
		$V_I = 4.6$ to $16 \text{ V}$ , $I_O = 500 \text{ mA}$				
		$V_I = 6 \text{ V}$	OFF MODE	50	120	$\mu\text{A}$
SVR	Supply voltage rejection	$I_O = 5 \text{ mA}$ , $V_I = 5.3 \pm 1 \text{ V}$ $T_a = 25^\circ\text{C}$	$f = 120 \text{ Hz}$	80		dB
			$f = 1 \text{ kHz}$	75		
			$f = 10 \text{ kHz}$	65		
eN	Output noise voltage	$B = 10 \text{ Hz}$ to $100 \text{ KHz}$ , $T_a = 25^\circ\text{C}$		50		$\mu\text{V}$
$V_d$	Dropout voltage	$I_O = 200 \text{ mA}$		0.2	1.3	V
		$I_O = 500 \text{ mA}$		0.4	1.3	
$V_{IL}$	Control input logic low				0.8	V
$V_{IH}$	Control input logic high		2			V
$I_I$	Control input current	$V_I = 6 \text{ V}$ , $V_C = 6 \text{ V}$ , $T_a = 25^\circ\text{C}$		10		$\mu\text{A}$
$C_O$	Output bypass capacitance	$\text{ESR} = 0.1$ to $10 \Omega$ , $I_O = 0$ to $500 \text{ mA}$	2	10		$\mu\text{F}$

**Table 16. Electrical characteristics for LF50AB** (refer to the test circuits,  $T_J = 25\text{ }^\circ\text{C}$ ,  $C_I = 0.1\text{ }\mu\text{F}$ ,  $C_O = 2.2\text{ }\mu\text{F}$  unless otherwise specified.)

Symbol	Parameter	Test conditions	Min.	Typ.	Max.	Unit
$V_O$	Output voltage	$I_O = 50\text{ mA}$ , $V_I = 7\text{ V}$	4.95	5	5.05	V
		$I_O = 50\text{ mA}$ , $V_I = 7\text{ V}$ , $T_a = -25\text{ to }85\text{ }^\circ\text{C}$	4.9		5.1	
$V_I$	Operating input voltage	$I_O = 500\text{ mA}$			16	V
$I_O$	Output current limit			1		A
$\Delta V_O$	Line regulation	$V_I = 6\text{ to }16\text{ V}$ , $I_O = 5\text{ mA}$		5	25	mV
$\Delta V_O$	Load regulation	$V_I = 6.3\text{ V}$ , $I_O = 5\text{ to }500\text{ mA}$		5	25	mV
$I_d$	Quiescent current	$V_I = 6\text{ to }16\text{ V}$ , $I_O = 0\text{ mA}$	ON MODE	0.5	1	mA
		$V_I = 6.3\text{ to }16\text{ V}$ , $I_O = 500\text{ mA}$			12	
		$V_I = 6\text{ V}$	OFF MODE	50	100	$\mu\text{A}$
SVR	Supply voltage rejection	$I_O = 5\text{ mA}$ , $V_I = 7 \pm 1\text{ V}$	$f = 120\text{ Hz}$	76		dB
			$f = 1\text{ kHz}$	71		
			$f = 10\text{ kHz}$	60		
eN	Output noise voltage	$B = 10\text{ Hz to }100\text{ kHz}$		50		$\mu\text{V}$
$V_d$	Dropout voltage	$I_O = 200\text{ mA}$		0.2	0.35	V
		$I_O = 500\text{ mA}$		0.4	0.7	
$V_{IL}$	Control input logic low	$T_a = -40\text{ to }125\text{ }^\circ\text{C}$			0.8	V
$V_{IH}$	Control input logic high	$T_a = -40\text{ to }125\text{ }^\circ\text{C}$	2			V
$I_I$	Control input current	$V_I = 6\text{ V}$ , $V_C = 6\text{ V}$		10		$\mu\text{A}$
$C_O$	Output bypass capacitance	$\text{ESR} = 0.1\text{ to }10\text{ }\Omega$ , $I_O = 0\text{ to }500\text{ mA}$	2	10		$\mu\text{F}$

**Table 17. Electrical characteristics for LF50ABDT-TRY (Automotive Grade)** (refer to the test circuits,  $T_A = -40$  to  $125^\circ\text{C}$ ,  $C_I = 0.1 \mu\text{F}$ ,  $C_O = 2.2 \mu\text{F}$  unless otherwise specified.)

Symbol	Parameter	Test conditions	Min.	Typ.	Max.	Unit
$V_O$	Output voltage	$I_O = 50 \text{ mA}$ , $V_I = 7 \text{ V}$ , $T_a = 25^\circ\text{C}$	4.95	5	5.05	V
		$I_O = 50 \text{ mA}$ , $V_I = 7 \text{ V}$	4.885		5.115	
$V_I$	Operating input voltage	$I_O = 500 \text{ mA}$			16	V
$I_O$	Output current limit	$T_a = 25^\circ\text{C}$		1		A
$\Delta V_O$	Line regulation	$V_I = 6$ to $16 \text{ V}$ , $I_O = 5 \text{ mA}$		5	28	mV
$\Delta V_O$	Load regulation	$V_I = 6.3 \text{ V}$ , $I_O = 5$ to $500 \text{ mA}$		5	28	mV
$I_d$	Quiescent current	$V_I = 6$ to $16 \text{ V}$ , $I_O = 0 \text{ mA}$	ON MODE	0.5	2	mA
		$V_I = 6.3$ to $16 \text{ V}$ , $I_O = 500 \text{ mA}$				
		$V_I = 6 \text{ V}$	OFF MODE	50	120	$\mu\text{A}$
SVR	Supply voltage rejection	$I_O = 5 \text{ mA}$ , $V_I = 7 \pm 1 \text{ V}$ $T_a = 25^\circ\text{C}$	$f = 120 \text{ Hz}$	76		dB
			$f = 1 \text{ kHz}$	71		
			$f = 10 \text{ kHz}$	60		
eN	Output noise voltage	$B = 10 \text{ Hz}$ to $100 \text{ kHz}$ , $T_a = 25^\circ\text{C}$		50		$\mu\text{V}$
$V_d$	Dropout voltage	$I_O = 200 \text{ mA}$		0.2	1.3	V
		$I_O = 500 \text{ mA}$		0.4	1.3	
$V_{IL}$	Control input logic low				0.8	V
$V_{IH}$	Control input logic high		2			V
$I_I$	Control input current	$V_I = 6 \text{ V}$ , $V_C = 6 \text{ V}$ , $T_a = 25^\circ\text{C}$		10		$\mu\text{A}$
$C_O$	Output bypass capacitance	$\text{ESR} = 0.1$ to $10 \Omega$ , $I_O = 0$ to $500 \text{ mA}$	2	10		$\mu\text{F}$

**Table 18. Electrical characteristics for LF50C** (refer to the test circuits,  $T_J = 25\text{ }^\circ\text{C}$ ,  $C_I = 0.1\text{ }\mu\text{F}$ ,  $C_O = 2.2\text{ }\mu\text{F}$  unless otherwise specified.)

Symbol	Parameter	Test conditions	Min.	Typ.	Max.	Unit
$V_O$	Output voltage	$I_O = 50\text{ mA}$ , $V_I = 7\text{ V}$	4.9	5	5.1	V
		$I_O = 50\text{ mA}$ , $V_I = 7\text{ V}$ , $T_a = -25\text{ to }85\text{ }^\circ\text{C}$	4.8		5.2	
$V_I$	Operating input voltage	$I_O = 500\text{ mA}$			16	V
$I_O$	Output current limit			1		A
$\Delta V_O$	Line regulation	$V_I = 6\text{ to }16\text{ V}$ , $I_O = 5\text{ mA}$		5	25	mV
$\Delta V_O$	Load regulation	$V_I = 6.3\text{ V}$ , $I_O = 5\text{ to }500\text{ mA}$		5	25	mV
$I_d$	Quiescent current	$V_I = 6\text{ to }16\text{ V}$ , $I_O = 0\text{ mA}$	ON MODE	0.5	1	mA
		$V_I = 6.3\text{ to }16\text{ V}$ , $I_O = 500\text{ mA}$			12	
		$V_I = 6\text{ V}$	OFF MODE	50	100	$\mu\text{A}$
SVR	Supply voltage rejection	$I_O = 5\text{ mA}$ , $V_I = 7 \pm 1\text{ V}$	$f = 120\text{ Hz}$	76		dB
			$f = 1\text{ kHz}$	71		
			$f = 10\text{ kHz}$	60		
eN	Output noise voltage	$B = 10\text{ Hz to }100\text{ kHz}$		50		$\mu\text{V}$
$V_d$	Dropout voltage	$I_O = 200\text{ mA}$		0.2	0.35	V
		$I_O = 500\text{ mA}$		0.4	0.7	
$V_{IL}$	Control input logic low	$T_a = -40\text{ to }125\text{ }^\circ\text{C}$			0.8	V
$V_{IH}$	Control input logic high	$T_a = -40\text{ to }125\text{ }^\circ\text{C}$	2			V
$I_I$	Control input current	$V_I = 6\text{ V}$ , $V_C = 6\text{ V}$		10		$\mu\text{A}$
$C_O$	Output bypass capacitance	$\text{ESR} = 0.1\text{ to }10\text{ }\Omega$ , $I_O = 0\text{ to }500\text{ mA}$	2	10		$\mu\text{F}$

**Table 19. Electrical characteristics for LF50CDT-TRY and LF50CPT-TRY (Automotive Grade)**  
(refer to the test circuits,  $T_A = -40$  to  $125^\circ\text{C}$ ,  $C_I = 0.1 \mu\text{F}$ ,  $C_O = 2.2 \mu\text{F}$  unless otherwise specified.)

Symbol	Parameter	Test conditions	Min.	Typ.	Max.	Unit
$V_O$	Output voltage	$I_O = 50 \text{ mA}$ , $V_I = 7 \text{ V}$ , $T_a = 25^\circ\text{C}$	4.9	5	5.1	V
		$I_O = 50 \text{ mA}$ , $V_I = 7 \text{ V}$	4.785		5.215	
$V_I$	Operating input voltage	$I_O = 500 \text{ mA}$			16	V
$I_O$	Output current limit	$T_a = 25^\circ\text{C}$		1		A
$\Delta V_O$	Line regulation	$V_I = 6$ to $16 \text{ V}$ , $I_O = 5 \text{ mA}$		5	28	mV
$\Delta V_O$	Load regulation	$V_I = 6.3 \text{ V}$ , $I_O = 5$ to $500 \text{ mA}$		5	28	mV
$I_d$	Quiescent current	$V_I = 6$ to $16 \text{ V}$ , $I_O = 0 \text{ mA}$	ON MODE	0.5	2	mA
		$V_I = 6.3$ to $16 \text{ V}$ , $I_O = 500 \text{ mA}$				
		$V_I = 6 \text{ V}$	OFF MODE	50	120	$\mu\text{A}$
SVR	Supply voltage rejection	$I_O = 5 \text{ mA}$ , $V_I = 7 \pm 1 \text{ V}$ $T_a = 25^\circ\text{C}$	$f = 120 \text{ Hz}$	76		dB
			$f = 1 \text{ kHz}$	71		
			$f = 10 \text{ kHz}$	60		
eN	Output noise voltage	$B = 10 \text{ Hz}$ to $100 \text{ kHz}$ , $T_a = 25^\circ\text{C}$		50		$\mu\text{V}$
$V_d$	Dropout voltage	$I_O = 200 \text{ mA}$		0.2	1.3	V
		$I_O = 500 \text{ mA}$		0.4	1.3	
$V_{IL}$	Control input logic low				0.8	V
$V_{IH}$	Control input logic high		2			V
$I_I$	Control input current	$V_I = 6 \text{ V}$ , $V_C = 6 \text{ V}$ , $T_a = 25^\circ\text{C}$		10		$\mu\text{A}$
$C_O$	Output bypass capacitance	$\text{ESR} = 0.1$ to $10 \Omega$ , $I_O = 0$ to $500 \text{ mA}$	2	10		$\mu\text{F}$

**Table 20. Electrical characteristics for LF60AB** (refer to the test circuits,  $T_J = 25\text{ }^\circ\text{C}$ ,  $C_1 = 0.1\text{ }\mu\text{F}$ ,  $C_O = 2.2\text{ }\mu\text{F}$  unless otherwise specified.)

Symbol	Parameter	Test conditions	Min.	Typ.	Max.	Unit
$V_O$	Output voltage	$I_O = 50\text{ mA}$ , $V_I = 8\text{ V}$	5.94	6	6.06	V
		$I_O = 50\text{ mA}$ , $V_I = 8\text{ V}$ , $T_a = -25\text{ to }85\text{ }^\circ\text{C}$	5.88		6.12	
$V_I$	Operating input voltage	$I_O = 500\text{ mA}$			16	V
$I_O$	Output current limit			1		A
$\Delta V_O$	Line regulation	$V_I = 7\text{ to }16\text{ V}$ , $I_O = 5\text{ mA}$		6	30	mV
$\Delta V_O$	Load regulation	$V_I = 7.3\text{ V}$ , $I_O = 5\text{ to }500\text{ mA}$		6	30	mV
$I_d$	Quiescent current	$V_I = 7\text{ to }16\text{ V}$ , $I_O = 0\text{ mA}$	ON MODE	0.7	1.5	mA
		$V_I = 7.3\text{ to }16\text{ V}$ , $I_O = 500\text{ mA}$				
		$V_I = 9\text{ V}$	OFF MODE	70	140	$\mu\text{A}$
SVR	Supply voltage rejection	$I_O = 5\text{ mA}$ , $V_I = 8 \pm 1\text{ V}$	$f = 120\text{ Hz}$	75		dB
			$f = 1\text{ kHz}$	70		
			$f = 10\text{ kHz}$	60		
eN	Output noise voltage	$B = 10\text{ Hz to }100\text{ kHz}$		50		$\mu\text{V}$
$V_d$	Dropout voltage	$I_O = 200\text{ mA}$		0.2	0.35	V
		$I_O = 500\text{ mA}$		0.4	0.7	
$V_{IL}$	Control input logic low	$T_a = -40\text{ to }125\text{ }^\circ\text{C}$			0.8	V
$V_{IH}$	Control input logic high	$T_a = -40\text{ to }125\text{ }^\circ\text{C}$	2			V
$I_I$	Control input current	$V_I = 9\text{ V}$ , $V_C = 6\text{ V}$		10		$\mu\text{A}$
$C_O$	Output bypass capacitance	$\text{ESR} = 0.1\text{ to }10\text{ }\Omega$ , $I_O = 0\text{ to }500\text{ mA}$	2	10		$\mu\text{F}$



**Table 21. Electrical characteristics for LF60C** (refer to the test circuits,  $T_J = 25\text{ }^\circ\text{C}$ ,  $C_I = 0.1\text{ }\mu\text{F}$ ,  $C_O = 2.2\text{ }\mu\text{F}$  unless otherwise specified.)

Symbol	Parameter	Test conditions	Min.	Typ.	Max.	Unit
$V_O$	Output voltage	$I_O = 50\text{ mA}$ , $V_I = 8\text{ V}$	5.88	6	6.12	V
		$I_O = 50\text{ mA}$ , $V_I = 8\text{ V}$ , $T_a = -25\text{ to }85\text{ }^\circ\text{C}$	5.76		6.24	
$V_I$	Operating input voltage	$I_O = 500\text{ mA}$			16	V
$I_O$	Output current limit			1		A
$\Delta V_O$	Line regulation	$V_I = 7\text{ to }16\text{ V}$ , $I_O = 5\text{ mA}$		6	30	mV
$\Delta V_O$	Load regulation	$V_I = 7.3\text{ V}$ , $I_O = 5\text{ to }500\text{ mA}$		6	30	mV
$I_d$	Quiescent current	$V_I = 7\text{ to }16\text{ V}$ , $I_O = 0\text{ mA}$	ON MODE	0.7	1.5	mA
		$V_I = 7.3\text{ to }16\text{ V}$ , $I_O = 500\text{ mA}$			12	
		$V_I = 9\text{ V}$	OFF MODE	70	140	$\mu\text{A}$
SVR	Supply voltage rejection	$I_O = 5\text{ mA}$ , $V_I = 8 \pm 1\text{ V}$	$f = 120\text{ Hz}$	75		dB
			$f = 1\text{ kHz}$	70		
			$f = 10\text{ kHz}$	60		
eN	Output noise voltage	$B = 10\text{ Hz to }100\text{ kHz}$		50		$\mu\text{V}$
$V_d$	Dropout voltage	$I_O = 200\text{ mA}$		0.2	0.35	V
		$I_O = 500\text{ mA}$		0.4	0.7	
$V_{IL}$	Control input logic low	$T_a = -40\text{ to }125\text{ }^\circ\text{C}$			0.8	V
$V_{IH}$	Control input logic high	$T_a = -40\text{ to }125\text{ }^\circ\text{C}$	2			V
$I_I$	Control input current	$V_I = 9\text{ V}$ , $V_C = 6\text{ V}$		10		$\mu\text{A}$
$C_O$	Output bypass capacitance	$\text{ESR} = 0.1\text{ to }10\text{ }\Omega$ , $I_O = 0\text{ to }500\text{ mA}$	2	10		$\mu\text{F}$

**Table 22. Electrical characteristics for LF80AB** (refer to the test circuits,  $T_J = 25\text{ °C}$ ,  $C_1 = 0.1\text{ }\mu\text{F}$ ,  $C_O = 2.2\text{ }\mu\text{F}$  unless otherwise specified.)

Symbol	Parameter	Test conditions	Min.	Typ.	Max.	Unit
$V_O$	Output voltage	$I_O = 50\text{ mA}$ , $V_I = 10\text{ V}$	7.92	8	8.08	V
		$I_O = 50\text{ mA}$ , $V_I = 10\text{ V}$ , $T_a = -25\text{ to }85\text{ °C}$	7.84		8.16	
$V_I$	Operating input voltage	$I_O = 500\text{ mA}$			16	V
$I_O$	Output current limit			1		A
$\Delta V_O$	Line regulation	$V_I = 9\text{ to }16\text{ V}$ , $I_O = 5\text{ mA}$		8	40	mV
$\Delta V_O$	Load regulation	$V_I = 9.3\text{ V}$ , $I_O = 5\text{ to }500\text{ mA}$		8	40	mV
$I_d$	Quiescent current	$V_I = 9\text{ to }16\text{ V}$ , $I_O = 0\text{ mA}$	ON MODE	0.7	1.5	mA
		$V_I = 9.3\text{ to }16\text{ V}$ , $I_O = 500\text{ mA}$				
		$V_I = 9\text{ V}$	OFF MODE	70	140	$\mu\text{A}$
SVR	Supply voltage rejection	$I_O = 5\text{ mA}$ , $V_I = 10 \pm 1\text{ V}$	$f = 120\text{ Hz}$	72		dB
			$f = 1\text{ kHz}$	67		
			$f = 10\text{ kHz}$	57		
eN	Output noise voltage	$B = 10\text{ Hz to }100\text{ kHz}$		50		$\mu\text{V}$
$V_d$	Dropout voltage	$I_O = 200\text{ mA}$		0.2	0.35	V
		$I_O = 500\text{ mA}$		0.4	0.7	
$V_{IL}$	Control input logic low	$T_a = -40\text{ to }125\text{ °C}$			0.8	V
$V_{IH}$	Control input logic high	$T_a = -40\text{ to }125\text{ °C}$	2			V
$I_I$	Control input current	$V_I = 9\text{ V}$ , $V_C = 6\text{ V}$		10		$\mu\text{A}$
$C_O$	Output bypass capacitance	$\text{ESR} = 0.1\text{ to }10\text{ }\Omega$ , $I_O = 0\text{ to }500\text{ mA}$	2	10		$\mu\text{F}$

**Table 23. Electrical characteristics for LF80C** (refer to the test circuits,  $T_J = 25\text{ }^\circ\text{C}$ ,  $C_I = 0.1\text{ }\mu\text{F}$ ,  $C_O = 2.2\text{ }\mu\text{F}$  unless otherwise specified.)

Symbol	Parameter	Test conditions	Min.	Typ.	Max.	Unit
$V_O$	Output voltage	$I_O = 50\text{ mA}$ , $V_I = 10\text{ V}$	7.84	8	8.16	V
		$I_O = 50\text{ mA}$ , $V_I = 10\text{ V}$ , $T_a = -25\text{ to }85\text{ }^\circ\text{C}$	7.68		8.32	
$V_I$	Operating input voltage	$I_O = 500\text{ mA}$			16	V
$I_O$	Output current limit			1		A
$\Delta V_O$	Line regulation	$V_I = 9\text{ to }16\text{ V}$ , $I_O = 5\text{ mA}$		8	40	mV
$\Delta V_O$	Load regulation	$V_I = 9.3\text{ V}$ , $I_O = 5\text{ to }500\text{ mA}$		8	40	mV
$I_d$	Quiescent current	$V_I = 9\text{ to }16\text{ V}$ , $I_O = 0\text{ mA}$	ON MODE	0.7	1.5	mA
		$V_I = 9.3\text{ to }16\text{ V}$ , $I_O = 500\text{ mA}$			12	
		$V_I = 9\text{ V}$	OFF MODE	70	140	$\mu\text{A}$
SVR	Supply voltage rejection	$I_O = 5\text{ mA}$ , $V_I = 10 \pm 1\text{ V}$	$f = 120\text{ Hz}$	72		dB
			$f = 1\text{ kHz}$	67		
			$f = 10\text{ kHz}$	57		
eN	Output noise voltage	$B = 10\text{ Hz to }100\text{ kHz}$		50		$\mu\text{V}$
$V_d$	Dropout voltage	$I_O = 200\text{ mA}$		0.2	0.35	V
		$I_O = 500\text{ mA}$		0.4	0.7	
$V_{IL}$	Control input logic low	$T_a = -40\text{ to }125\text{ }^\circ\text{C}$			0.8	V
$V_{IH}$	Control input logic high	$T_a = -40\text{ to }125\text{ }^\circ\text{C}$	2			V
$I_I$	Control input current	$V_I = 9\text{ V}$ , $V_C = 6\text{ V}$		10		$\mu\text{A}$
$C_O$	Output bypass capacitance	$\text{ESR} = 0.1\text{ to }10\text{ }\Omega$ , $I_O = 0\text{ to }500\text{ mA}$	2	10		$\mu\text{F}$

**Table 24. Electrical characteristics for LF80CDT-TRY (Automotive Grade)** (refer to the test circuits,  $T_A = -40$  to  $125^\circ\text{C}$ ,  $C_I = 0.1 \mu\text{F}$ ,  $C_O = 2.2 \mu\text{F}$  unless otherwise specified.)

Symbol	Parameter	Test conditions	Min.	Typ.	Max.	Unit
$V_O$	Output voltage	$I_O = 50 \text{ mA}$ , $V_I = 10 \text{ V}$ , $T_a = 25^\circ\text{C}$	7.84	8	8.16	V
		$I_O = 50 \text{ mA}$ , $V_I = 10 \text{ V}$	7.665		8.335	
$V_I$	Operating input voltage	$I_O = 500 \text{ mA}$			16	V
$I_O$	Output current limit	$T_a = 25^\circ\text{C}$		1		A
$\Delta V_O$	Line regulation	$V_I = 9$ to $16 \text{ V}$ , $I_O = 5 \text{ mA}$		8	44	mV
$\Delta V_O$	Load regulation	$V_I = 9.3 \text{ V}$ , $I_O = 5$ to $500 \text{ mA}$		8	44	mV
$I_d$	Quiescent current	$V_I = 9$ to $16 \text{ V}$ , $I_O = 0 \text{ mA}$	ON MODE	0.7	2.5	mA
		$V_I = 9.3$ to $16 \text{ V}$ , $I_O = 500 \text{ mA}$				
		$V_I = 9 \text{ V}$	OFF MODE	70	160	$\mu\text{A}$
SVR	Supply voltage rejection	$I_O = 5 \text{ mA}$ , $V_I = 10 \pm 1 \text{ V}$ $T_a = 25^\circ\text{C}$	$f = 120 \text{ Hz}$	72		dB
			$f = 1 \text{ kHz}$	67		
			$f = 10 \text{ kHz}$	57		
eN	Output noise voltage	$B = 10 \text{ Hz}$ to $100 \text{ kHz}$ , $T_a = 25^\circ\text{C}$		50		$\mu\text{V}$
$V_d$	Dropout voltage	$I_O = 200 \text{ mA}$		0.2	1.3	V
		$I_O = 500 \text{ mA}$		0.4	1.3	
$V_{IL}$	Control input logic low				0.8	V
$V_{IH}$	Control input logic high		2			V
$I_I$	Control input current	$V_I = 9 \text{ V}$ , $V_C = 6 \text{ V}$ , $T_a = 25^\circ\text{C}$		10		$\mu\text{A}$
$C_O$	Output bypass capacitance	$\text{ESR} = 0.1$ to $10 \Omega$ , $I_O = 0$ to $500 \text{ mA}$	2	10		$\mu\text{F}$

**Table 25. Electrical characteristics for LF85AB** (refer to the test circuits,  $T_J = 25\text{ °C}$ ,  $C_I = 0.1\text{ }\mu\text{F}$ ,  $C_O = 2.2\text{ }\mu\text{F}$  unless otherwise specified.)

Symbol	Parameter	Test conditions	Min.	Typ.	Max.	Unit
$V_O$	Output voltage	$I_O = 50\text{ mA}$ , $V_I = 10.5\text{ V}$	8.415	8.5	8.585	V
		$I_O = 50\text{ mA}$ , $V_I = 10.5\text{ V}$ , $T_a = -25\text{ to }85\text{ °C}$	8.33		8.67	
$V_I$	Operating input voltage	$I_O = 500\text{ mA}$			16	V
$I_O$	Output current limit			1		A
$\Delta V_O$	Line regulation	$V_I = 9.5\text{ to }16\text{ V}$ , $I_O = 5\text{ mA}$		8	42	mV
$\Delta V_O$	Load regulation	$V_I = 9.8\text{ V}$ , $I_O = 5\text{ to }500\text{ mA}$		8	42	mV
$I_d$	Quiescent current	$V_I = 9.5\text{ to }16\text{ V}$ , $I_O = 0\text{ mA}$	ON MODE	0.7	1.5	mA
		$V_I = 9.8\text{ to }16\text{ V}$ , $I_O = 500\text{ mA}$				
		$V_I = 9\text{ V}$	OFF MODE	70	140	$\mu\text{A}$
SVR	Supply voltage rejection	$I_O = 5\text{ mA}$ , $V_I = 10.5 \pm 1\text{ V}$	$f = 120\text{ Hz}$	72		dB
			$f = 1\text{ kHz}$	67		
			$f = 10\text{ kHz}$	57		
eN	Output noise voltage	$B = 10\text{ Hz to }100\text{ kHz}$		50		$\mu\text{V}$
$V_d$	Dropout voltage	$I_O = 200\text{ mA}$		0.2	0.35	V
		$I_O = 500\text{ mA}$		0.4	0.7	
$V_{IL}$	Control input logic low	$T_a = -40\text{ to }125\text{ °C}$			0.8	V
$V_{IH}$	Control input logic high	$T_a = -40\text{ to }125\text{ °C}$	2			V
$I_I$	Control input current	$V_I = 9\text{ V}$ , $V_C = 6\text{ V}$		10		$\mu\text{A}$
$C_O$	Output bypass capacitance	$\text{ESR} = 0.1\text{ to }10\text{ }\Omega$ , $I_O = 0\text{ to }500\text{ mA}$	2	10		$\mu\text{F}$

**Table 26. Electrical characteristics for LF85C** (refer to the test circuits,  $T_J = 25\text{ }^\circ\text{C}$ ,  $C_I = 0.1\text{ }\mu\text{F}$ ,  $C_O = 2.2\text{ }\mu\text{F}$  unless otherwise specified.)

Symbol	Parameter	Test conditions	Min.	Typ.	Max.	Unit
$V_O$	Output voltage	$I_O = 50\text{ mA}$ , $V_I = 10.5\text{ V}$	8.33	8.5	8.67	V
		$I_O = 50\text{ mA}$ , $V_I = 10.5\text{ V}$ , $T_a = -25\text{ to }85\text{ }^\circ\text{C}$	8.16		8.84	
$V_I$	Operating input voltage	$I_O = 500\text{ mA}$			16	V
$I_O$	Output current limit			1		A
$\Delta V_O$	Line regulation	$V_I = 9.5\text{ to }16\text{ V}$ , $I_O = 5\text{ mA}$		8	42	mV
$\Delta V_O$	Load regulation	$V_I = 9.8\text{ V}$ , $I_O = 5\text{ to }500\text{ mA}$		8	42	mV
$I_d$	Quiescent current	$V_I = 9.5\text{ to }16\text{ V}$ , $I_O = 0\text{ mA}$	ON MODE	0.7	1.5	mA
		$V_I = 9.8\text{ to }16\text{ V}$ , $I_O = 500\text{ mA}$			12	
		$V_I = 9\text{ V}$	OFF MODE	70	140	$\mu\text{A}$
SVR	Supply voltage rejection	$I_O = 5\text{ mA}$ , $V_I = 10.5 \pm 1\text{ V}$	$f = 120\text{ Hz}$	72		dB
			$f = 1\text{ kHz}$	67		
			$f = 10\text{ kHz}$	57		
eN	Output noise voltage	$B = 10\text{ Hz to }100\text{ kHz}$		50		$\mu\text{V}$
$V_d$	Dropout voltage	$I_O = 200\text{ mA}$		0.2	0.35	V
		$I_O = 500\text{ mA}$		0.4	0.7	
$V_{IL}$	Control input logic low	$T_a = -40\text{ to }125\text{ }^\circ\text{C}$			0.8	V
$V_{IH}$	Control input logic high	$T_a = -40\text{ to }125\text{ }^\circ\text{C}$	2			V
$I_I$	Control input current	$V_I = 9\text{ V}$ , $V_C = 6\text{ V}$		10		$\mu\text{A}$
$C_O$	Output bypass capacitance	$\text{ESR} = 0.1\text{ to }10\text{ }\Omega$ , $I_O = 0\text{ to }500\text{ mA}$	2	10		$\mu\text{F}$

**Table 27. Electrical characteristics for LF85CDT-TRY and LF85CPT-TRY (Automotive Grade)**  
(refer to the test circuits,  $T_A = -40$  to  $25^\circ\text{C}$ ,  $C_I = 0.1 \mu\text{F}$ ,  $C_O = 2.2 \mu\text{F}$  unless otherwise specified.)

Symbol	Parameter	Test conditions	Min.	Typ.	Max.	Unit
$V_O$	Output voltage	$I_O = 50 \text{ mA}$ , $V_I = 10.5 \text{ V}$ , $T_a = 25^\circ\text{C}$	8.33	8.5	8.67	V
		$I_O = 50 \text{ mA}$ , $V_I = 10.5 \text{ V}$	8.145		8.855	
$V_I$	Operating input voltage	$I_O = 500 \text{ mA}$			16	V
$I_O$	Output current limit	$T_a = 25^\circ\text{C}$		1		A
$\Delta V_O$	Line regulation	$V_I = 9.5$ to $16 \text{ V}$ , $I_O = 5 \text{ mA}$		8	44	mV
$\Delta V_O$	Load regulation	$V_I = 9.8 \text{ V}$ , $I_O = 5$ to $500 \text{ mA}$		8	44	mV
$I_d$	Quiescent current	$V_I = 9.5$ to $16 \text{ V}$ , $I_O = 0 \text{ mA}$	ON MODE	0.7	2.5	mA
		$V_I = 9.8$ to $16 \text{ V}$ , $I_O = 500 \text{ mA}$				
		$V_I = 9 \text{ V}$	OFF MODE	70	160	$\mu\text{A}$
SVR	Supply voltage rejection	$I_O = 5 \text{ mA}$ , $V_I = 10.5 \pm 1 \text{ V}$ $T_a = 25^\circ\text{C}$	$f = 120 \text{ Hz}$	72		dB
			$f = 1 \text{ kHz}$	67		
			$f = 10 \text{ kHz}$	57		
eN	Output noise voltage	$B = 10 \text{ Hz}$ to $100 \text{ kHz}$ , $T_a = 25^\circ\text{C}$		50		$\mu\text{V}$
$V_d$	Dropout voltage	$I_O = 200 \text{ mA}$		0.2	1.3	V
		$I_O = 500 \text{ mA}$		0.4	1.3	
$V_{IL}$	Control input logic low				0.8	V
$V_{IH}$	Control input logic high		2			V
$I_I$	Control input current	$V_I = 9 \text{ V}$ , $V_C = 6 \text{ V}$ , $T_a = 25^\circ\text{C}$		10		$\mu\text{A}$
$C_O$	Output bypass capacitance	$\text{ESR} = 0.1$ to $10 \Omega$ , $I_O = 0$ to $500 \text{ mA}$	2	10		$\mu\text{F}$

**Table 28. Electrical characteristics for LF90AB** (refer to the test circuits,  $T_J = 25\text{ }^\circ\text{C}$ ,  $C_I = 0.1\text{ }\mu\text{F}$ ,  $C_O = 2.2\text{ }\mu\text{F}$  unless otherwise specified.)

Symbol	Parameter	Test conditions	Min.	Typ.	Max.	Unit
$V_O$	Output voltage	$I_O = 50\text{ mA}$ , $V_I = 11\text{ V}$	8.91	9	9.09	V
		$I_O = 50\text{ mA}$ , $V_I = 11\text{ V}$ , $T_a = -25\text{ to }85\text{ }^\circ\text{C}$	8.82		9.18	
$V_I$	Operating input voltage	$I_O = 500\text{ mA}$			16	V
$I_O$	Output current limit			1		A
$\Delta V_O$	Line regulation	$V_I = 10\text{ to }16\text{ V}$ , $I_O = 5\text{ mA}$		9	45	mV
$\Delta V_O$	Load regulation	$V_I = 10.3\text{ V}$ , $I_O = 5\text{ to }500\text{ mA}$		9	45	mV
$I_d$	Quiescent current	$V_I = 10\text{ to }16\text{ V}$ , $I_O = 0\text{ mA}$	ON MODE	0.7	1.5	mA
		$V_I = 10.3\text{ to }16\text{ V}$ , $I_O = 500\text{ mA}$			12	
		$V_I = 10\text{ V}$	OFF MODE	70	140	$\mu\text{A}$
SVR	Supply voltage rejection	$I_O = 5\text{ mA}$ , $V_I = 11 \pm 1\text{ V}$	$f = 120\text{ Hz}$	71		dB
			$f = 1\text{ kHz}$	66		
			$f = 10\text{ kHz}$	56		
eN	Output noise voltage	$B = 10\text{ Hz to }100\text{ kHz}$		50		$\mu\text{V}$
$V_d$	Dropout voltage	$I_O = 200\text{ mA}$		0.2	0.35	V
		$I_O = 500\text{ mA}$		0.4	0.7	
$V_{IL}$	Control input logic low	$T_a = -40\text{ to }125\text{ }^\circ\text{C}$			0.8	V
$V_{IH}$	Control input logic high	$T_a = -40\text{ to }125\text{ }^\circ\text{C}$	2			V
$I_I$	Control input current	$V_I = 10\text{ V}$ , $V_C = 6\text{ V}$		10		$\mu\text{A}$
$C_O$	Output bypass capacitance	$\text{ESR} = 0.1\text{ to }10\text{ }\Omega$ , $I_O = 0\text{ to }500\text{ mA}$	2	10		$\mu\text{F}$



**Table 29. Electrical characteristics for LF90C** (refer to the test circuits,  $T_J = 25\text{ }^\circ\text{C}$ ,  $C_I = 0.1\text{ }\mu\text{F}$ ,  $C_O = 2.2\text{ }\mu\text{F}$  unless otherwise specified.)

Symbol	Parameter	Test conditions	Min.	Typ.	Max.	Unit
$V_O$	Output voltage	$I_O = 50\text{ mA}$ , $V_I = 11\text{ V}$	8.82	9	9.18	V
		$I_O = 50\text{ mA}$ , $V_I = 11\text{ V}$ , $T_a = -25\text{ to }85\text{ }^\circ\text{C}$	8.64		9.36	
$V_I$	Operating input voltage	$I_O = 500\text{ mA}$			16	V
$I_O$	Output current limit			1		A
$\Delta V_O$	Line regulation	$V_I = 10\text{ to }16\text{ V}$ , $I_O = 5\text{ mA}$		9	45	mV
$\Delta V_O$	Load regulation	$V_I = 10.3\text{ V}$ , $I_O = 5\text{ to }500\text{ mA}$		9	45	mV
$I_d$	Quiescent current	$V_I = 10\text{ to }16\text{ V}$ , $I_O = 0\text{ mA}$	ON MODE	0.7	1.5	mA
		$V_I = 10.3\text{ to }16\text{ V}$ , $I_O = 500\text{ mA}$			12	
		$V_I = 10\text{ V}$	OFF MODE	70	140	$\mu\text{A}$
SVR	Supply voltage rejection	$I_O = 5\text{ mA}$ , $V_I = 11 \pm 1\text{ V}$	$f = 120\text{ Hz}$	71		dB
			$f = 1\text{ kHz}$	66		
			$f = 10\text{ kHz}$	56		
eN	Output noise voltage	$B = 10\text{ Hz to }100\text{ kHz}$		50		$\mu\text{V}$
$V_d$	Dropout voltage	$I_O = 200\text{ mA}$		0.2	0.35	V
		$I_O = 500\text{ mA}$		0.4	0.7	
$V_{IL}$	Control input logic low	$T_a = -40\text{ to }125\text{ }^\circ\text{C}$			0.8	V
$V_{IH}$	Control input logic high	$T_a = -40\text{ to }125\text{ }^\circ\text{C}$	2			V
$I_I$	Control input current	$V_I = 10\text{ V}$ , $V_C = 6\text{ V}$		10		$\mu\text{A}$
$C_O$	Output bypass capacitance	$\text{ESR} = 0.1\text{ to }10\text{ }\Omega$ , $I_O = 0\text{ to }500\text{ mA}$	2	10		$\mu\text{F}$

**Table 30. Electrical characteristics for LF120AB** (refer to the test circuits,  $T_J = 25\text{ }^\circ\text{C}$ ,  $C_1 = 0.1\text{ }\mu\text{F}$ ,  $C_O = 2.2\text{ }\mu\text{F}$  unless otherwise specified.)

Symbol	Parameter	Test conditions	Min.	Typ.	Max.	Unit
$V_O$	Output voltage	$I_O = 50\text{ mA}$ , $V_I = 15\text{ V}$	11.88	12	12.12	V
		$I_O = 50\text{ mA}$ , $V_I = 15\text{ V}$ , $T_a = -25\text{ to }85\text{ }^\circ\text{C}$	11.76		12.24	
$V_I$	Operating input voltage	$I_O = 500\text{ mA}$			16	V
$I_O$	Output current limit			1		A
$\Delta V_O$	Line regulation	$V_I = 13\text{ to }16\text{ V}$ , $I_O = 5\text{ mA}$		12	60	mV
$\Delta V_O$	Load regulation	$V_I = 13.3\text{ V}$ , $I_O = 5\text{ to }500\text{ mA}$		12	60	mV
$I_d$	Quiescent current	$V_I = 13\text{ to }16\text{ V}$ , $I_O = 0\text{ mA}$	ON MODE	0.7	1.5	mA
		$V_I = 13.3\text{ to }16\text{ V}$ , $I_O = 500\text{ mA}$			12	
		$V_I = 13\text{ V}$	OFF MODE		70	140
SVR	Supply voltage rejection	$I_O = 5\text{ mA}$ , $V_I = 14 \pm 1\text{ V}$	$f = 120\text{ Hz}$		69	dB
			$f = 1\text{ kHz}$		64	
			$f = 10\text{ kHz}$		54	
eN	Output noise voltage	$B = 10\text{ Hz to }100\text{ kHz}$		50		$\mu\text{V}$
$V_d$	Dropout voltage	$I_O = 200\text{ mA}$		0.2	0.35	V
		$I_O = 500\text{ mA}$		0.4	0.7	
$V_{IL}$	Control input logic low	$T_a = -40\text{ to }125\text{ }^\circ\text{C}$			0.8	V
$V_{IH}$	Control input logic high	$T_a = -40\text{ to }125\text{ }^\circ\text{C}$	2			V
$I_I$	Control input current	$V_I = 13\text{ V}$ , $V_C = 6\text{ V}$		10		$\mu\text{A}$
$C_O$	Output bypass capacitance	$\text{ESR} = 0.1\text{ to }10\text{ }\Omega$ , $I_O = 0\text{ to }500\text{ mA}$	2	10		$\mu\text{F}$

**Table 31. Electrical characteristics for LF120C** (refer to the test circuits,  $T_J = 25\text{ }^\circ\text{C}$ ,  $C_I = 0.1\text{ }\mu\text{F}$ ,  $C_O = 2.2\text{ }\mu\text{F}$  unless otherwise specified).

Symbol	Parameter	Test conditions	Min.	Typ.	Max.	Unit	
$V_O$	Output voltage	$I_O = 50\text{ mA}$ , $V_I = 14\text{ V}$	11.76	12	12.24	V	
		$I_O = 50\text{ mA}$ , $V_I = 14\text{ V}$ , $T_a = -25\text{ to }85\text{ }^\circ\text{C}$	11.52		12.48		
$V_I$	Operating input voltage	$I_O = 500\text{ mA}$			16	V	
$I_O$	Output current limit			1		A	
$\Delta V_O$	Line regulation	$V_I = 13\text{ to }16\text{ V}$ , $I_O = 5\text{ mA}$		12	60	mV	
$\Delta V_O$	Load regulation	$V_I = 13.3\text{ V}$ , $I_O = 5\text{ to }500\text{ mA}$		12	60	mV	
$I_d$	Quiescent current	$V_I = 13\text{ to }16\text{ V}$ , $I_O = 0\text{ mA}$	ON MODE		0.7	1.5	mA
		$V_I = 13.3\text{ to }16\text{ V}$ , $I_O = 500\text{ mA}$				12	
		$V_I = 13\text{ V}$	OFF MODE		70	140	$\mu\text{A}$
SVR	Supply voltage rejection	$I_O = 5\text{ mA}$ , $V_I = 14 \pm 1\text{ V}$	$f = 120\text{ Hz}$		69	dB	
			$f = 1\text{ kHz}$		64		
			$f = 10\text{ kHz}$		54		
eN	Output noise voltage	$B = 10\text{ Hz to }100\text{ kHz}$		50		$\mu\text{V}$	
$V_d$	Dropout voltage	$I_O = 200\text{ mA}$		0.2	0.35	V	
		$I_O = 500\text{ mA}$		0.4	0.7		
$V_{IL}$	Control input logic low	$T_a = -40\text{ to }125\text{ }^\circ\text{C}$			0.8	V	
$V_{IH}$	Control input logic high	$T_a = -40\text{ to }125\text{ }^\circ\text{C}$	2			V	
$I_I$	Control input current	$V_I = 13\text{ V}$ , $V_C = 6\text{ V}$		10		$\mu\text{A}$	
$C_O$	Output bypass capacitance	$\text{ESR} = 0.1\text{ to }10\text{ }\Omega$ , $I_O = 0\text{ to }500\text{ mA}$	2	10		$\mu\text{F}$	

# 5 Typical performance characteristics

(unless otherwise specified  $V_{O(NOM)} = 3.3\text{ V}$ )

**Figure 4. Dropout voltage vs output current**      **Figure 5. Dropout voltage vs temperature**

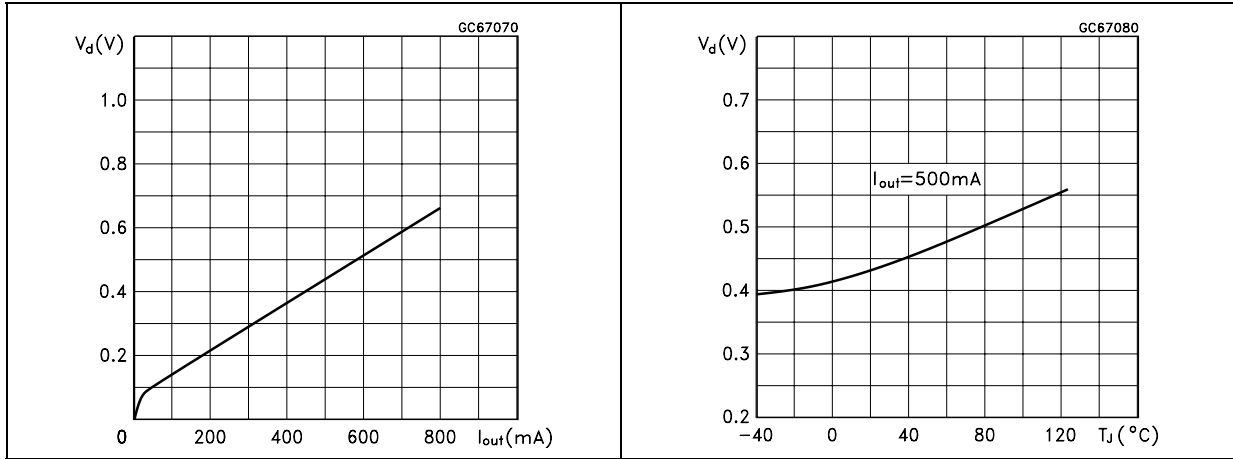

**Figure 6. Supply current vs input voltage**      **Figure 7. Supply current vs input voltage**

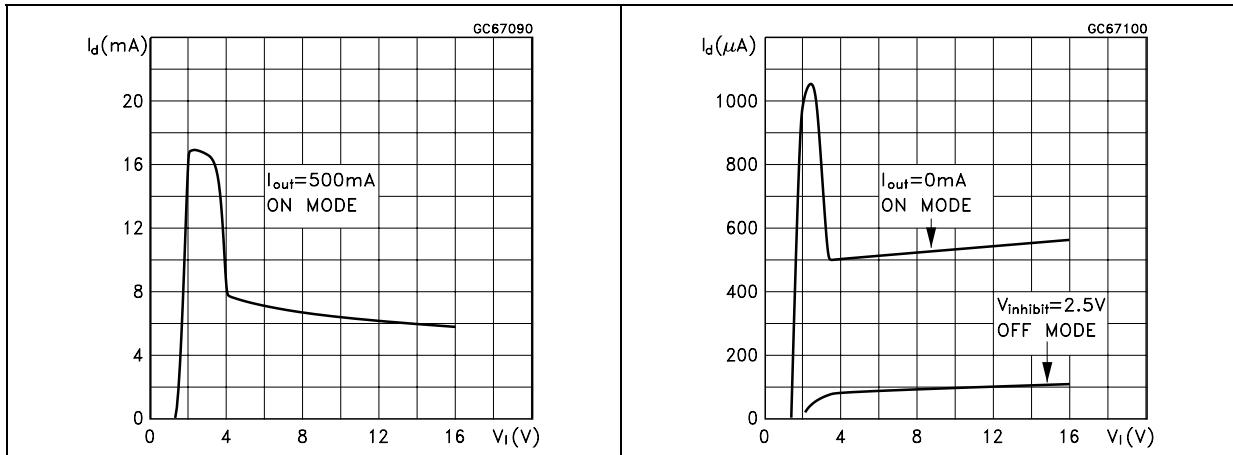

**Figure 8. Short circuit current vs input voltage**      **Figure 9. Supply current vs temperature**

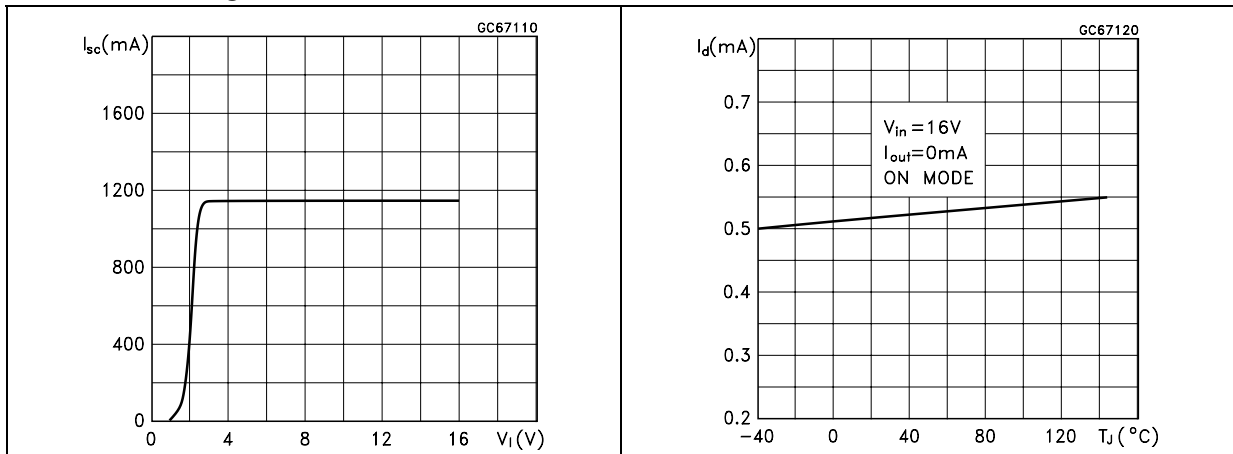

Figure 10. Logic controlled precision 3.3/5.0 V selectable output

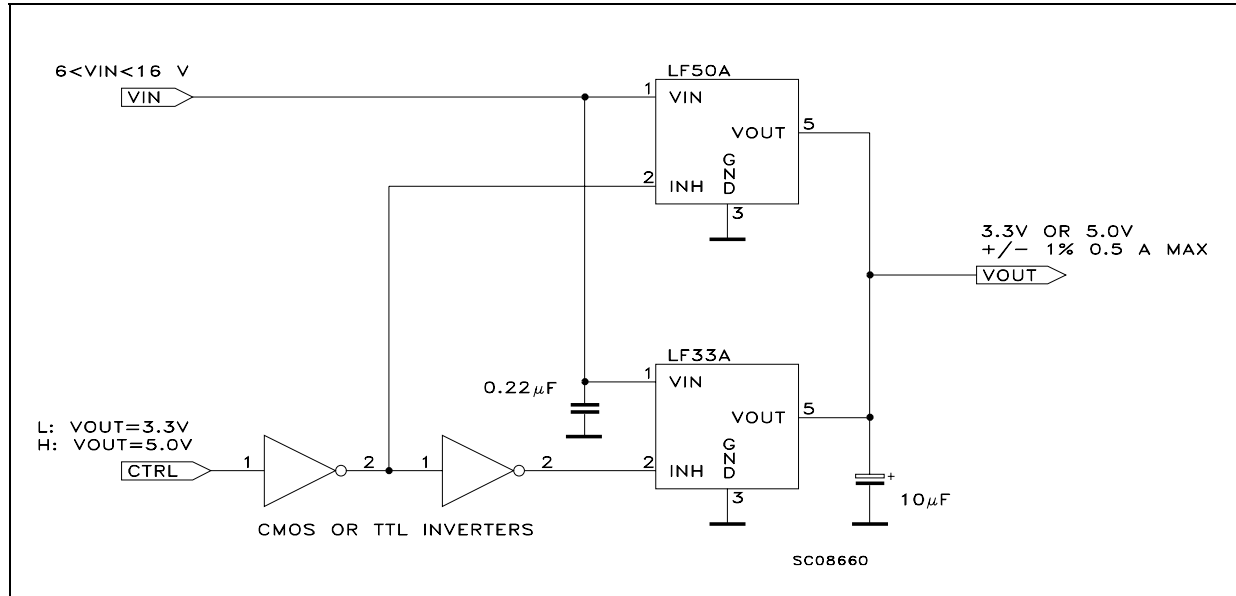

Figure 11. Sequential multi-output supply

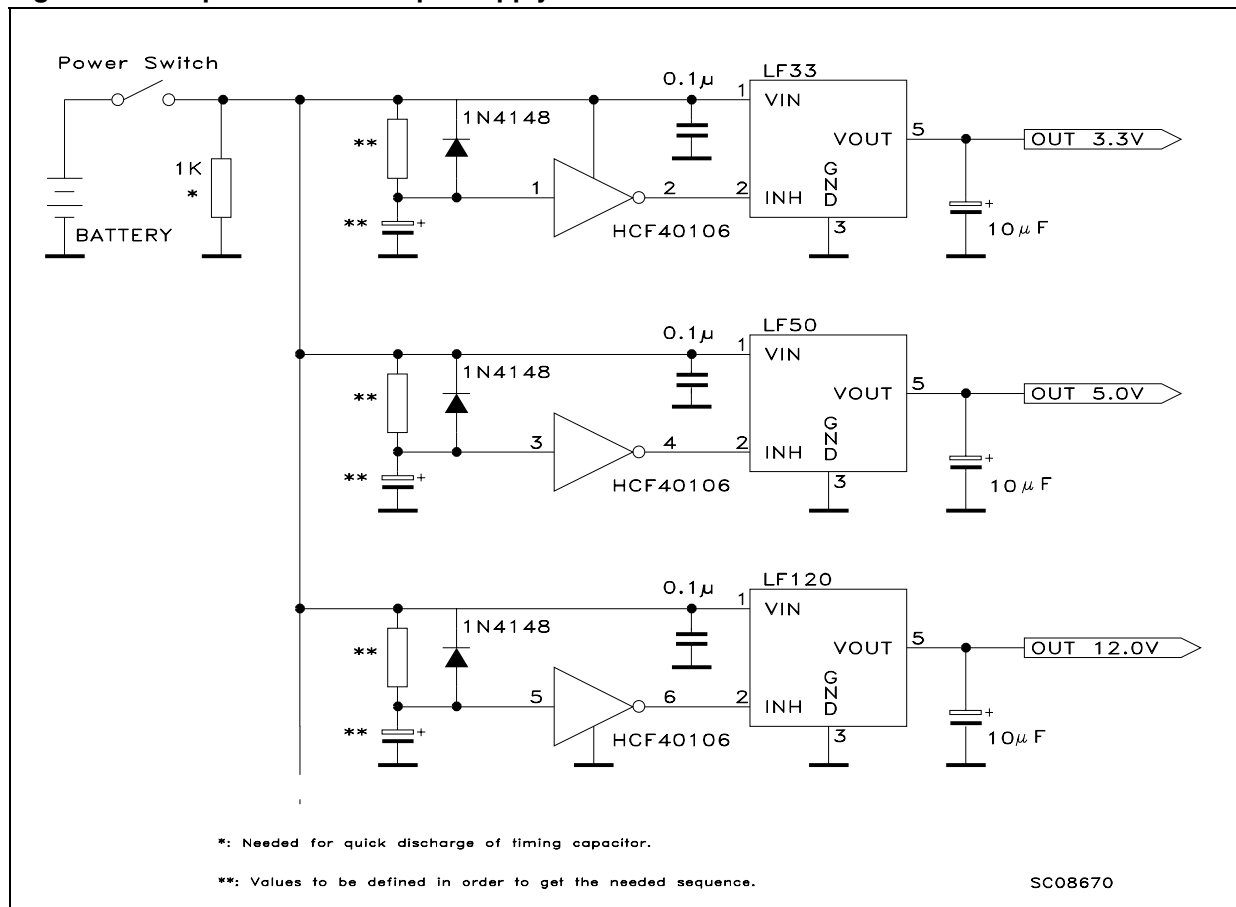

Figure 12. Multiple supply with ON/OFF toggle switch

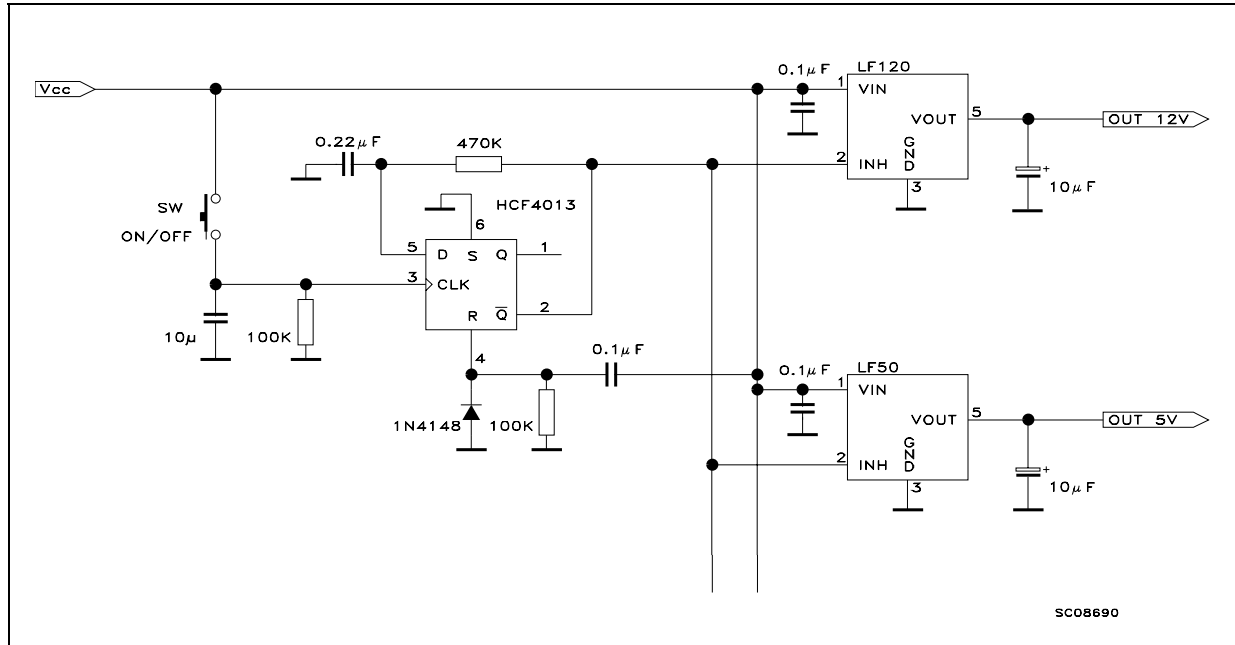

Figure 13. Basic inhibit functions

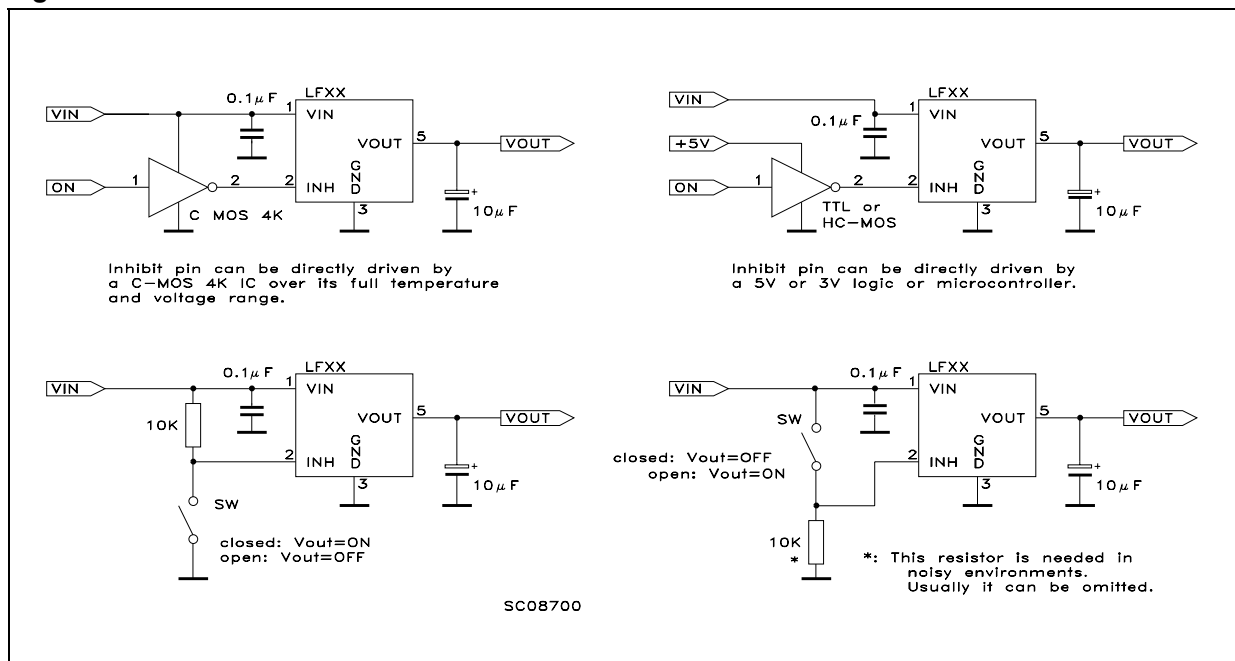

Figure 14. Delayed turn-on

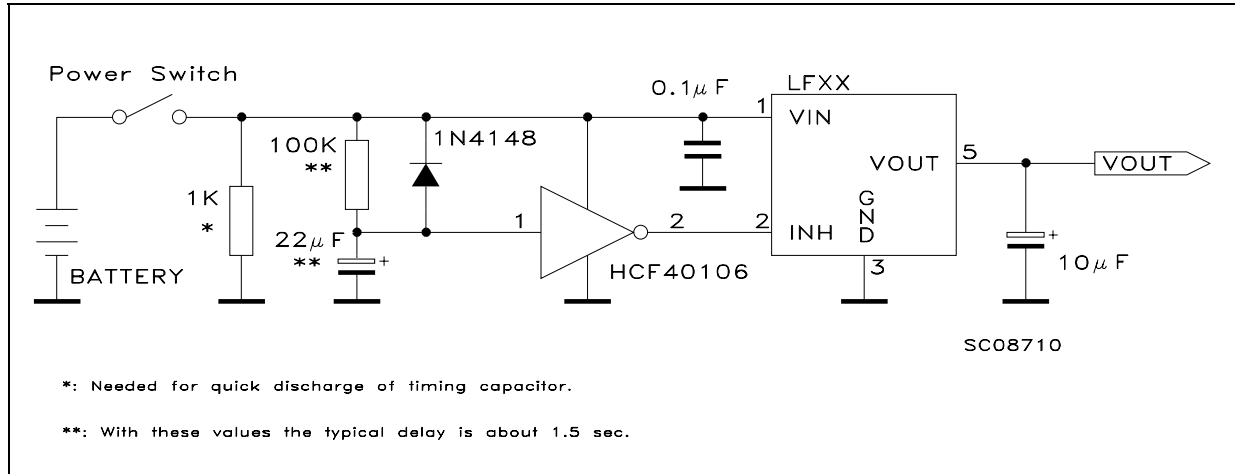
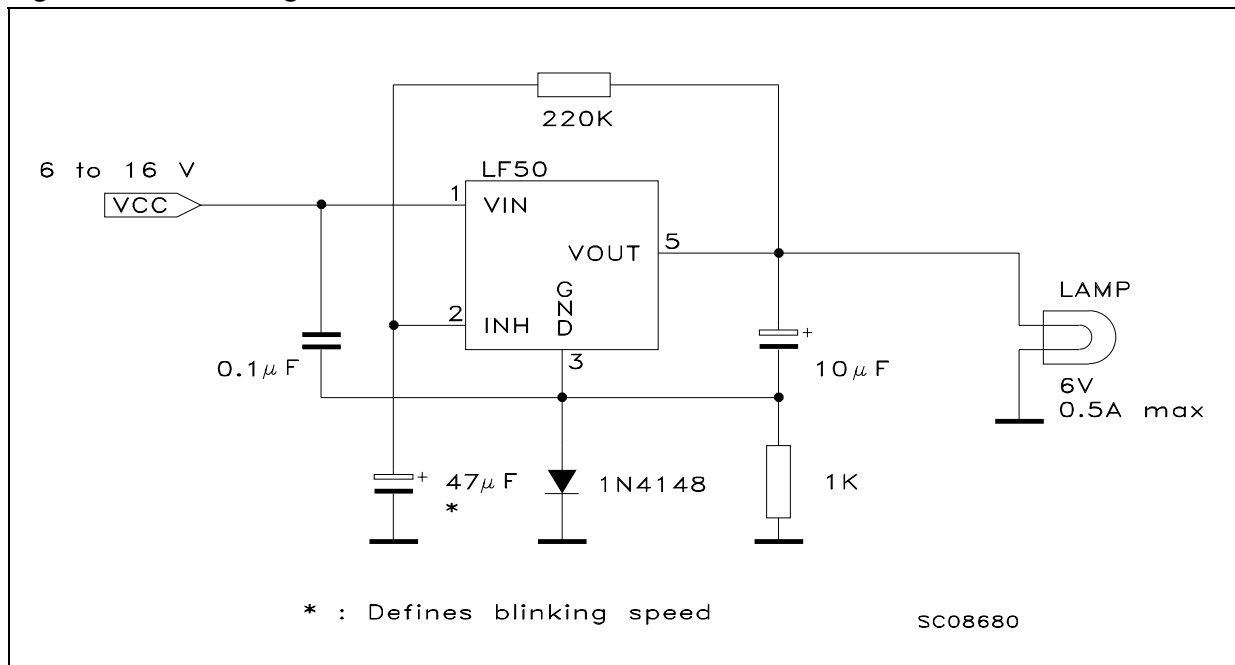

Figure 15. Low voltage bulb blinker



## 6 Package mechanical data

In order to meet environmental requirements, ST offers these devices in ECOPACK<sup>®</sup> packages. These packages have a lead-free second level interconnect. The category of second Level Interconnect is marked on the package and on the inner box label, in compliance with JEDEC Standard JESD97. The maximum ratings related to soldering conditions are also marked on the inner box label. ECOPACK is an ST trademark. ECOPACK specifications are available at: [www.st.com](http://www.st.com).



**PENTAWATT (Vertical) mechanical data**

Dim.	mm.			inch.		
	Min.	Typ.	Max.	Min.	Typ.	Max.
A			4.8			0.189
C			1.37			0.054
D	2.4		2.8	0.094		0.110
D1	1.2		1.35	0.047		0.053
E	0.35		0.55	0.014		0.022
F	0.8		1.05	0.031		0.041
F1	1		1.4	0.039		0.055
G	3.2	3.4	3.6	0.126	0.134	0.142
G1	6.6	6.8	7	0.260	0.268	0.276
H2			10.4			0.409
H3	10.05		10.4	0.396		0.409
L		17.85			0.703	
L1		15.75			0.620	
L2		21.4			0.843	
L3		22.5			0.886	
L5	2.6		3	0.102		0.118
L6	15.1		15.8	0.594		0.622
L7	6		6.6	0.236		0.260
M		4.5			0.177	
M1		4			0.157	
Dia1	3.65		3.85	0.144		0.152

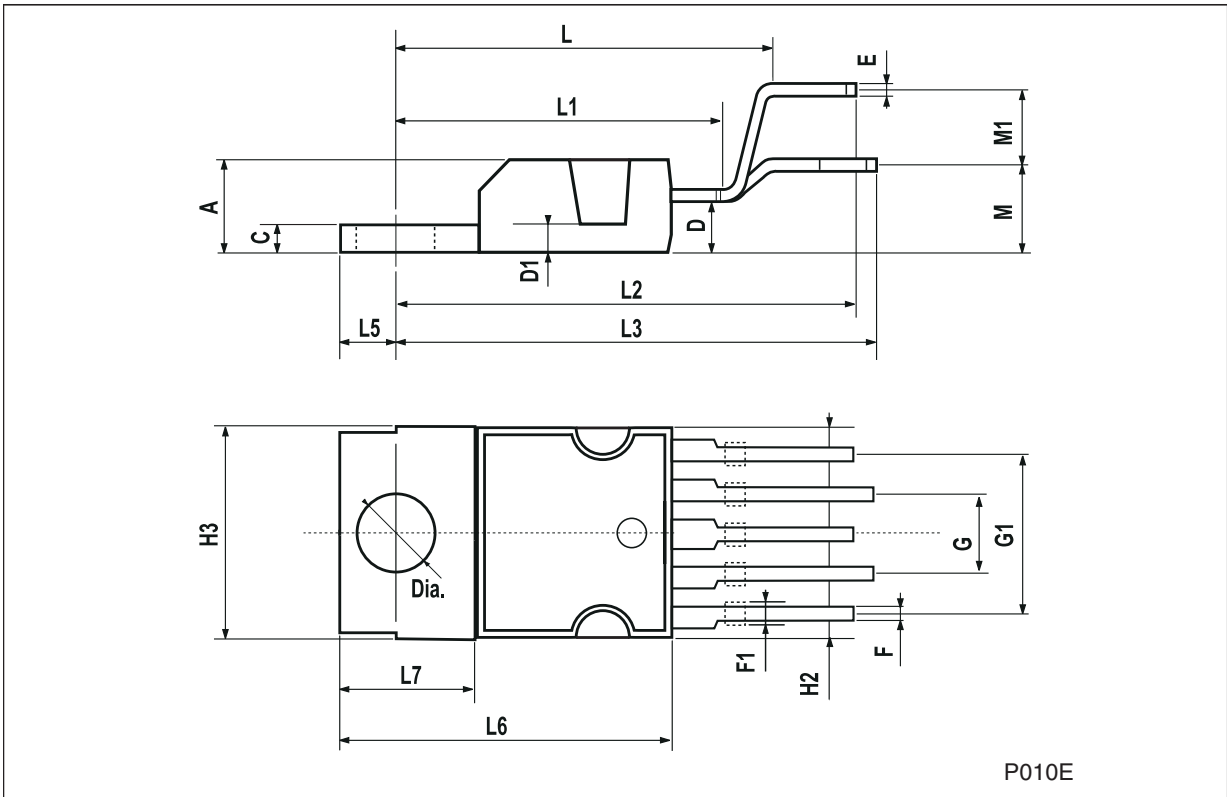

P010E

**TO-220 mechanical data**

Dim.	mm.			inch.		
	Min.	Typ.	Max.	Min.	Typ.	Max.
A	4.40		4.60	0.173		0.181
C	1.23		1.32	0.048		0.051
D	2.40		2.72	0.094		0.107
D1		1.27			0.050	
E	0.49		0.70	0.019		0.027
F	0.61		0.88	0.024		0.034
F1	1.14		1.70	0.044		0.067
F2	1.14		1.70	0.044		0.067
G	4.95		5.15	0.194		0.203
G1	2.4		2.7	0.094		0.106
H2	10.0		10.40	0.393		0.409
L2		16.4			0.645	
L4	13.0		14.0	0.511		0.551
L5	2.65		2.95	0.104		0.116
L6	15.25		15.75	0.600		0.620
L7	6.2		6.6	0.244		0.260
L9	3.5		3.93	0.137		0.154
DIA.	3.75		3.85	0.147		0.151

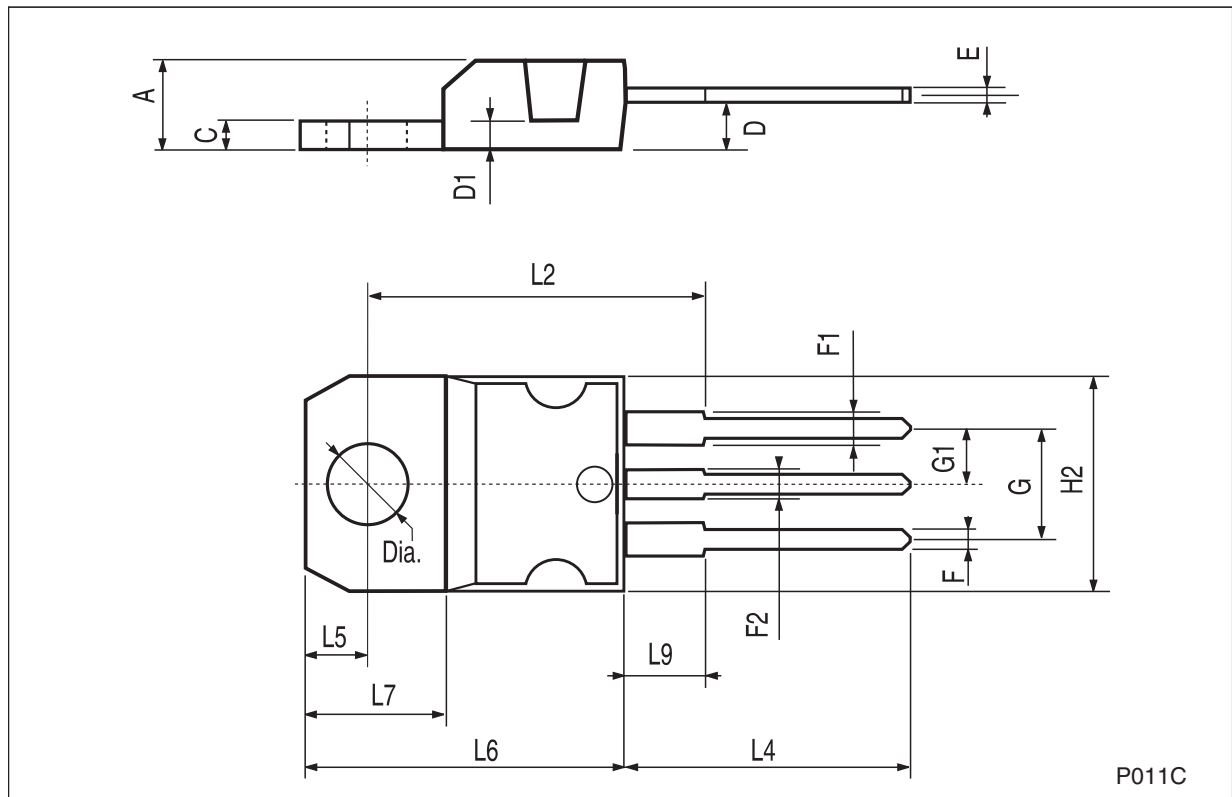

**TO-220FP mechanical data**

Dim.	mm.			inch.		
	Min.	Typ	Max.	Min.	Typ.	Max.
A	4.40		4.60	0.173		0.181
B	2.5		2.7	0.098		0.106
D	2.5		2.75	0.098		0.108
E	0.45		0.70	0.017		0.027
F	0.75		1	0.030		0.039
F1	1.15		1.50	0.045		0.059
F2	1.15		1.50	0.045		0.059
G	4.95		5.2	0.194		0.204
G1	2.4		2.7	0.094		0.106
H	10.0		10.40	0.393		0.409
L2		16			0.630	
L3	28.6		30.6	1.126		1.204
L4	9.8		10.6	0.385		0.417
L5	2.9		3.6	0.114		0.142
L6	15.9		16.4	0.626		0.645
L7	9		9.3	0.354		0.366
DIA.	3		3.2	0.118		0.126

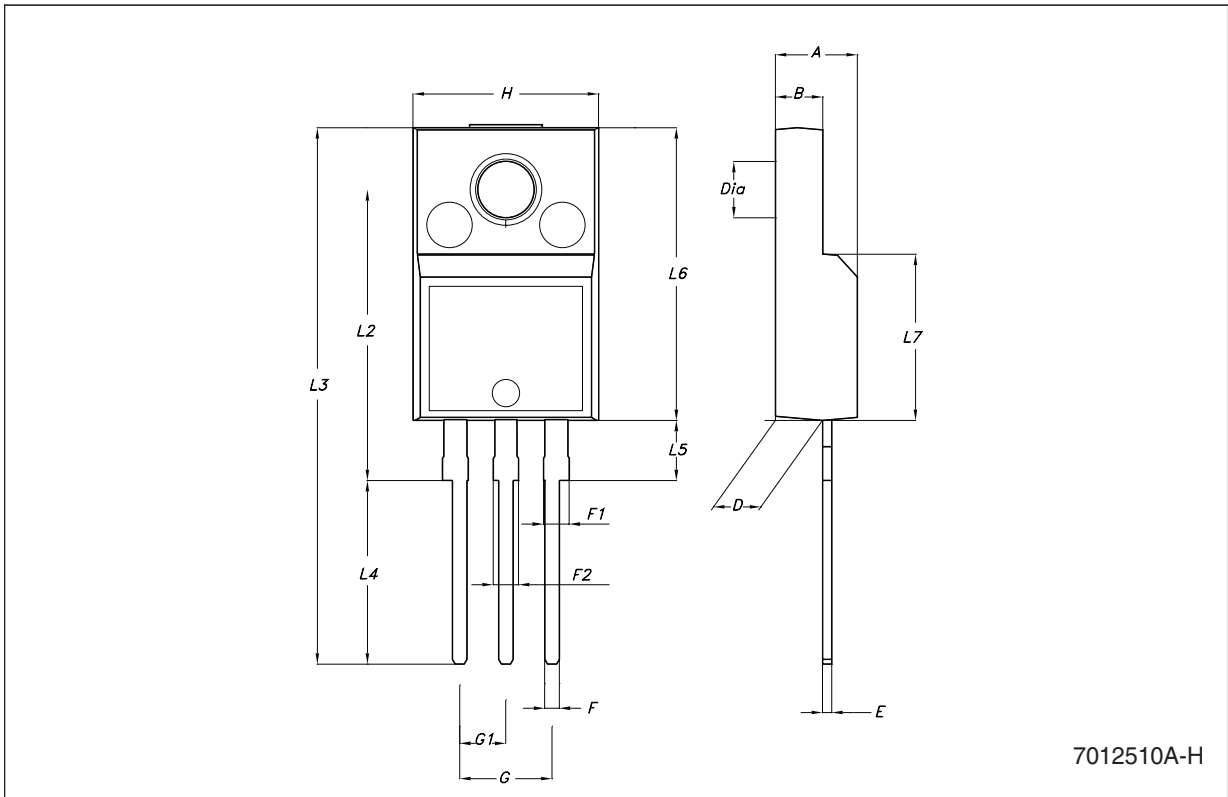

**DPAK mechanical data**

Dim.	mm.			inch.		
	Min.	Typ.	Max.	Min.	Typ.	Max.
A	2.2		2.4	0.086		0.094
A1	0.9		1.1	0.035		0.043
A2	0.03		0.23	0.001		0.009
B	0.64		0.9	0.025		0.035
b4	5.2		5.4	0.204		0.212
C	0.45		0.6	0.017		0.023
C2	0.48		0.6	0.019		0.023
D	6		6.2	0.236		0.244
D1		5.1			0.200	
E	6.4		6.6	0.252		0.260
E1		4.7			0.185	
e		2.28			0.090	
e1	4.4		4.6	0.173		0.181
H	9.35		10.1	0.368		0.397
L	1			0.039		
(L1)		2.8			0.110	
L2		0.8			0.031	
L4	0.6		1	0.023		0.039
R		0.2			0.008	
V2	0°		8°	0°		8°

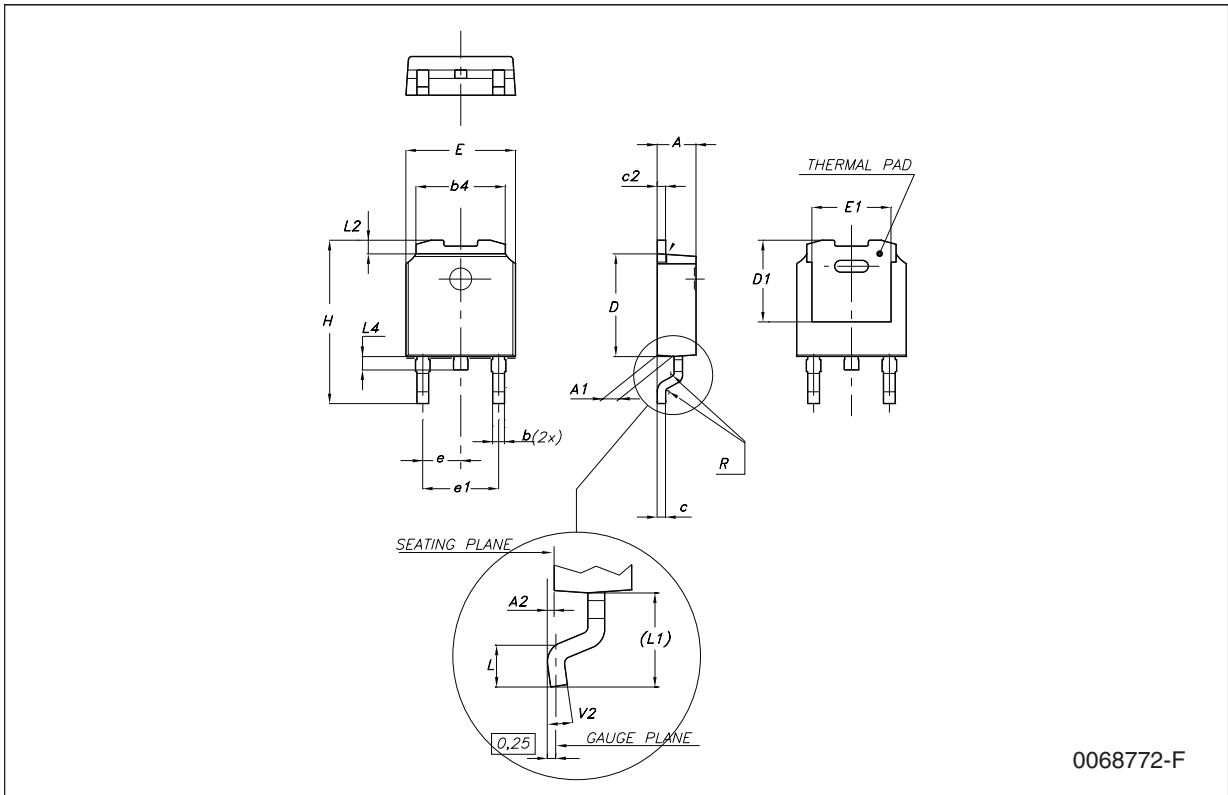

0068772-F

**PPAK mechanical data**

Dim.	mm.			inch.		
	Min.	Typ.	Max.	Min.	Typ.	Max.
A	2.2		2.4	0.086		0.094
A1	0.9		1.1	0.035		0.043
A2	0.03		0.23	0.001		0.009
B	0.4		0.6	0.015		0.023
B2	5.2		5.4	0.204		0.212
C	0.45		0.6	0.017		0.023
C2	0.48		0.6	0.019		0.023
D	6		6.2	0.236		0.244
D1		5.1			0.201	
E	6.4		6.6	0.252		0.260
E1		4.7			0.185	
e		1.27			0.050	
G	4.9		5.25	0.193		0.206
G1	2.38		2.7	0.093		0.106
H	9.35		10.1	0.368		0.397
L2		0.8	1		0.031	0.039
L4	0.6		1	0.023		0.039
L5	1			0.039		
L6		2.8			0.110	

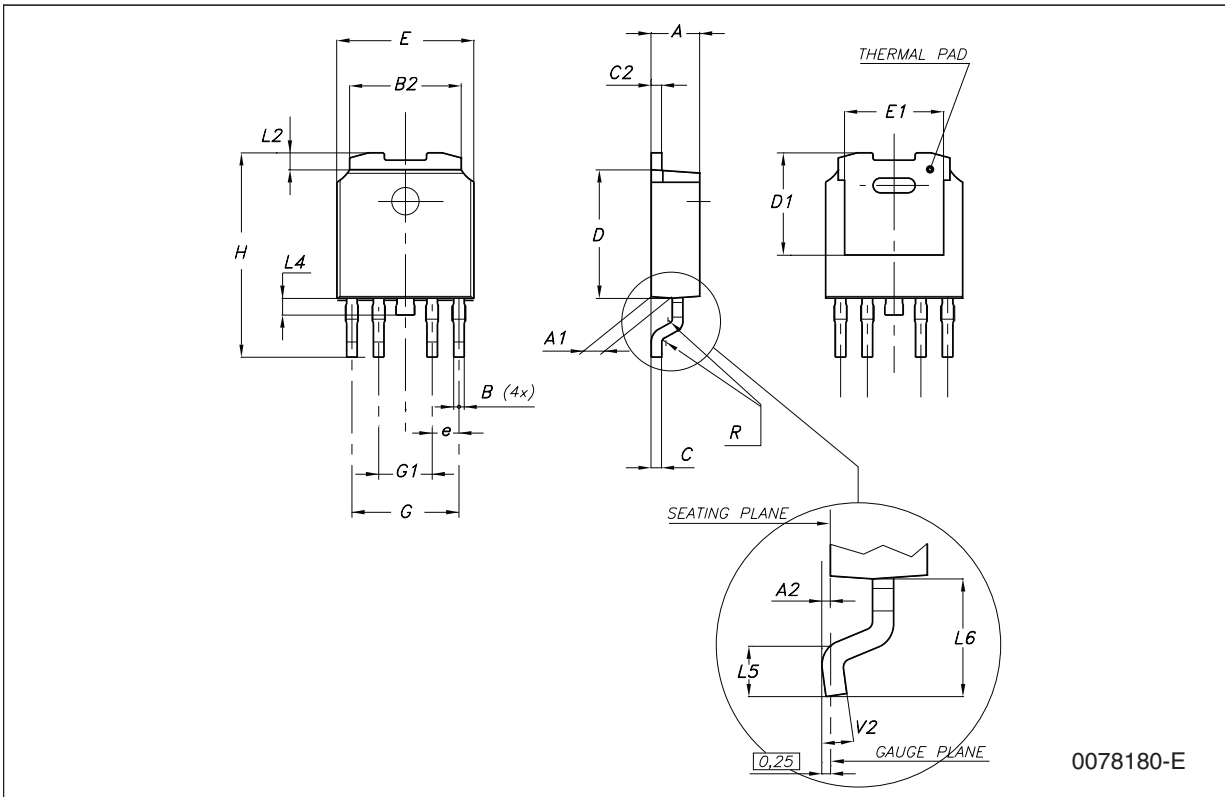

0078180-E

**Tape & reel DPAK-PPAK mechanical data**

Dim.	mm.			inch.		
	Min.	Typ.	Max.	Min.	Typ.	Max.
A			330			12.992
C	12.8	13.0	13.2	0.504	0.512	0.519
D	20.2			0.795		
N	60			2.362		
T			22.4			0.882
Ao	6.80	6.90	7.00	0.268	0.272	0.276
Bo	10.40	10.50	10.60	0.409	0.413	0.417
Ko	2.55	2.65	2.75	0.100	0.104	0.105
Po	3.9	4.0	4.1	0.153	0.157	0.161
P	7.9	8.0	8.1	0.311	0.315	0.319

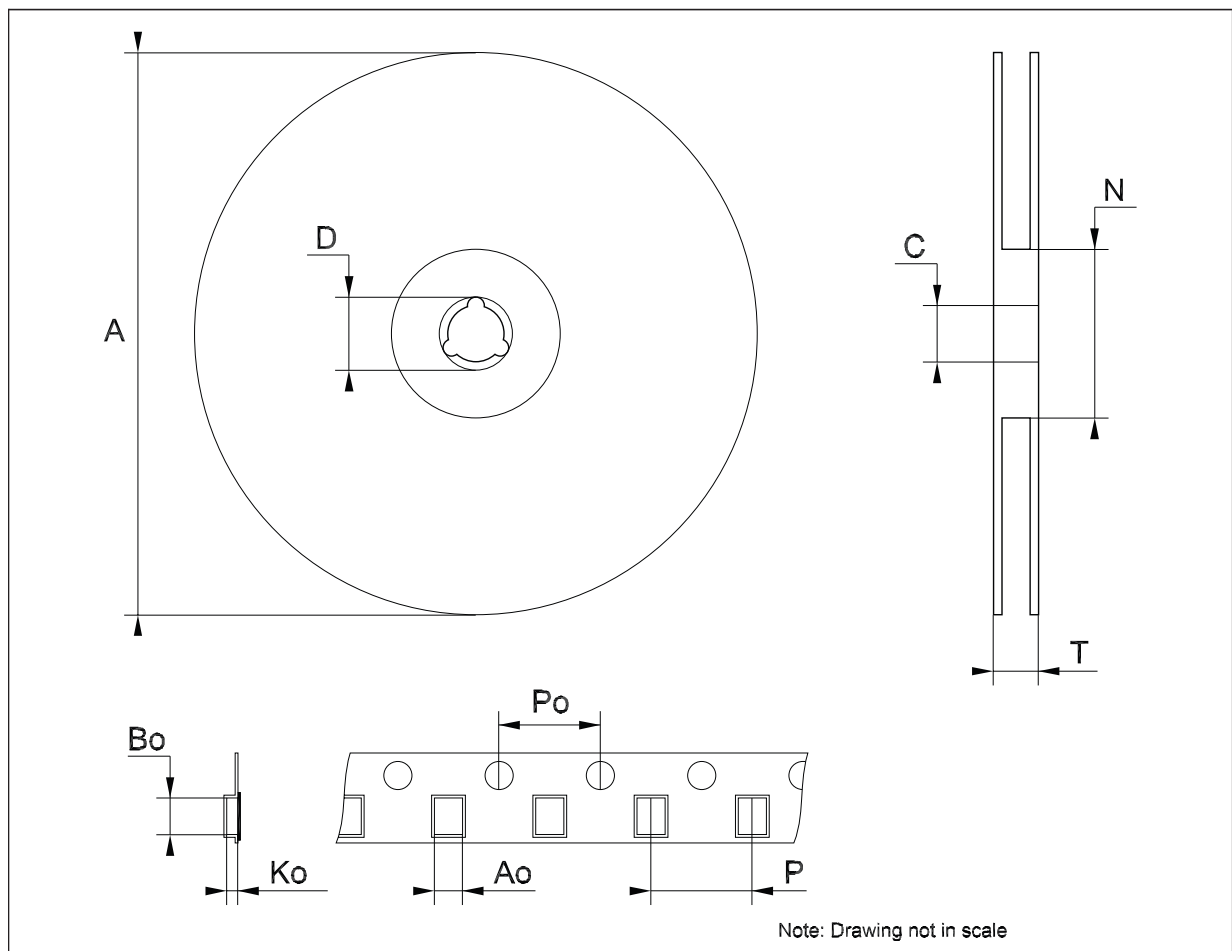

## 7 Order codes

Table 32. Order codes

Packages						Output voltage
TO-220	TO-220FP	DPAK	DPAK (T&R)	PPAK	PPAK (T&R)	
LF15CV <sup>(1)</sup>	LF15CP <sup>(1)</sup>			LF15CPT <sup>(1)</sup>	LF15CPT-TR <sup>(1)</sup>	1.5 V
LF15ABV <sup>(1)</sup>	LF15ABP <sup>(1)</sup>		LF15ABDT-TR	LF15ABPT <sup>(1)</sup>		1.5 V
	LF18CP <sup>(1)</sup>		LF18CDT-TR		LF18CPT-TR	1.8 V
			LF18CDT-TRY <sup>(2)</sup>			1.8 V
	LF18ABP <sup>(1)</sup>		LF18ABDT-TR		LF18ABPT-TR	1.8 V
	LF25CP <sup>(1)</sup>		LF25CDT-TR		LF25CPT-TR	2.5 V
			LF25CDT-TRY <sup>(2)</sup>			2.5 V
	LF25ABP <sup>(1)</sup>		LF25ABDT-TR	LF25ABPT <sup>(1)</sup>		2.5 V
			LF25ABDT-TRY <sup>(2)</sup>			2.5 V
LF33CV			LF33CDT-TR		LF33CPT-TR	3.3 V
			LF33CDT-TRY <sup>(2)</sup>		LF33CPT-TRY <sup>(2)</sup>	3.3 V
LF33ABV			LF33ABDT-TR			3.3 V
LF47CV						4.7 V
LF50CV	LF50CP		LF50CDT-TR		LF50CPT-TR	5 V
			LF50CDT-TRY <sup>(2)</sup>		LF50CPT-TRY <sup>(2)</sup>	5 V
LF50ABV	LF50ABP		LF50ABDT-TR		LF50ABPT-TR	5 V
			LF50ABDT-TRY <sup>(2)</sup>			5 V
LF60CV	LF60CP <sup>(1)</sup>		LF60CDT-TR		LF60CPT-TR <sup>(1)</sup>	6 V
LF60ABV	LF60ABP <sup>(1)</sup>		LF60ABDT-TR	LF60ABPT <sup>(1)</sup>	LF60ABPT-TR <sup>(1)</sup>	6 V
LF80CV	LF80CP <sup>(1)</sup>		LF80CDT-TR		LF80CPT-TR	8 V
			LF80CDT-TRY <sup>(2)</sup>			8 V
LF80ABV	LF80ABP <sup>(1)</sup>		LF80ABDT-TR			8 V
			LF85CDT-TR		LF85CPT-TR	8.5 V
			LF85CDT-TRY <sup>(2)</sup>		LF85CPT-TRY <sup>(2)</sup>	8.5 V
				LF85ABPT <sup>(1)</sup>	LF85ABPT-TR	8.5 V
LF90CV	LF90CP <sup>(1)</sup>		LF90CDT-TR		LF90CPT-TR	9 V
	LF90ABP <sup>(1)</sup>	LF90ABDT <sup>(1)</sup>	LF90ABDT-TR		LF90ABPT-TR	9 V
	LF120CP <sup>(1)</sup>		LF120CDT-TR			12 V
LF120ABV			LF120ABDT-TR	LF120ABPT <sup>(1)</sup>		12 V

1. Available on request.

2. Automotive Grade products.

## 8 Revision history

**Table 33. Document revision history**

Date	Revision	Changes
21-Jun-2004	14	Document updating.
24-May-2006	15	Order codes updated.
02-Apr-2007	16	Order codes updated.
14-May-2007	17	Order codes updated.
26-Jul-2007	18	Add <a href="#">Table 1</a> in cover page.
26-Nov-2007	19	Modified: <a href="#">Table 32</a> .
16-Jan-2008	20	Added new order codes for Automotive grade products see <a href="#">Table 32 on page 47</a> .
12-Feb-2008	21	Modified: <a href="#">Table 32 on page 47</a> .
10-Jul-2008	22	Modified: <a href="#">Table 32 on page 47</a> .



**Please Read Carefully:**

Information in this document is provided solely in connection with ST products. STMicroelectronics NV and its subsidiaries ("ST") reserve the right to make changes, corrections, modifications or improvements, to this document, and the products and services described herein at any time, without notice.

All ST products are sold pursuant to ST's terms and conditions of sale.

Purchasers are solely responsible for the choice, selection and use of the ST products and services described herein, and ST assumes no liability whatsoever relating to the choice, selection or use of the ST products and services described herein.

No license, express or implied, by estoppel or otherwise, to any intellectual property rights is granted under this document. If any part of this document refers to any third party products or services it shall not be deemed a license grant by ST for the use of such third party products or services, or any intellectual property contained therein or considered as a warranty covering the use in any manner whatsoever of such third party products or services or any intellectual property contained therein.

**UNLESS OTHERWISE SET FORTH IN ST'S TERMS AND CONDITIONS OF SALE ST DISCLAIMS ANY EXPRESS OR IMPLIED WARRANTY WITH RESPECT TO THE USE AND/OR SALE OF ST PRODUCTS INCLUDING WITHOUT LIMITATION IMPLIED WARRANTIES OF MERCHANTABILITY, FITNESS FOR A PARTICULAR PURPOSE (AND THEIR EQUIVALENTS UNDER THE LAWS OF ANY JURISDICTION), OR INFRINGEMENT OF ANY PATENT, COPYRIGHT OR OTHER INTELLECTUAL PROPERTY RIGHT.**

**UNLESS EXPRESSLY APPROVED IN WRITING BY AN AUTHORIZED ST REPRESENTATIVE, ST PRODUCTS ARE NOT RECOMMENDED, AUTHORIZED OR WARRANTED FOR USE IN MILITARY, AIR CRAFT, SPACE, LIFE SAVING, OR LIFE SUSTAINING APPLICATIONS, NOR IN PRODUCTS OR SYSTEMS WHERE FAILURE OR MALFUNCTION MAY RESULT IN PERSONAL INJURY, DEATH, OR SEVERE PROPERTY OR ENVIRONMENTAL DAMAGE. ST PRODUCTS WHICH ARE NOT SPECIFIED AS "AUTOMOTIVE GRADE" MAY ONLY BE USED IN AUTOMOTIVE APPLICATIONS AT USER'S OWN RISK.**

Resale of ST products with provisions different from the statements and/or technical features set forth in this document shall immediately void any warranty granted by ST for the ST product or service described herein and shall not create or extend in any manner whatsoever, any liability of ST.

ST and the ST logo are trademarks or registered trademarks of ST in various countries.

Information in this document supersedes and replaces all information previously supplied.

The ST logo is a registered trademark of STMicroelectronics. All other names are the property of their respective owners.

© 2008 STMicroelectronics - All rights reserved

STMicroelectronics group of companies

Australia - Belgium - Brazil - Canada - China - Czech Republic - Finland - France - Germany - Hong Kong - India - Israel - Italy - Japan - Malaysia - Malta - Morocco - Singapore - Spain - Sweden - Switzerland - United Kingdom - United States of America

[www.st.com](http://www.st.com)