

1 2 3 4 5 6

A

B

C

D

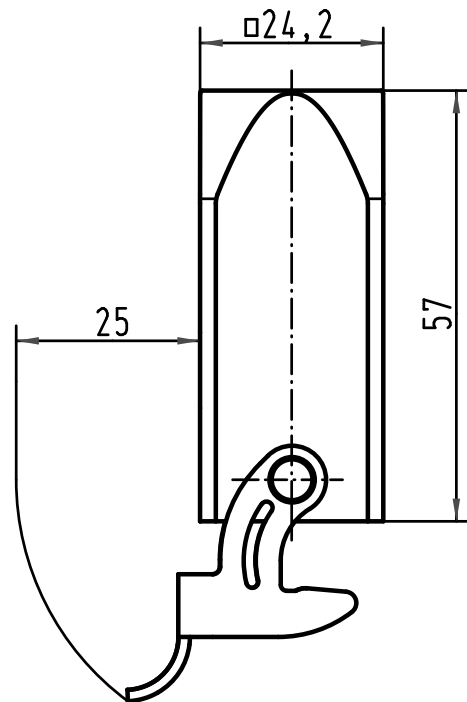
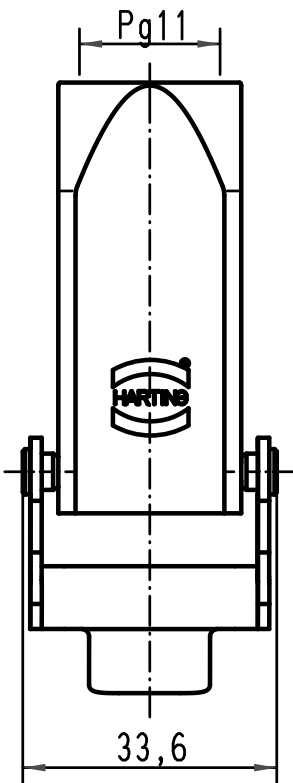
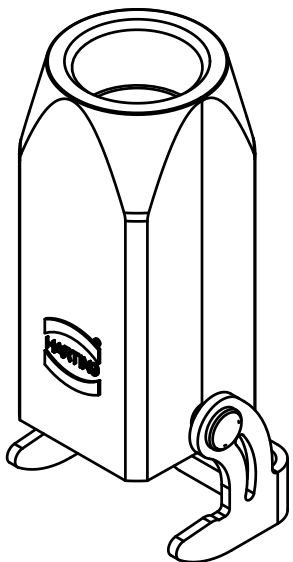

All Dimensions in mm Original Size DIN A 4			Techn. Character.			Nicht tolerierte Maß/Free size tolerances		
				Dat.	Name	Maßstab/Scale 1:1	Han 3A-kg-Pg11 Kupplungsgehäuse/ hoods cable to cable	
			Detail.	04.02.93	MEIER			
			Insp.		SDT			
414280	08.12.08	ML	Stand.					
30196	09.11.01	DY	HARTING Electric GmbH & Co. KG				TB 09 20 003 1750	
25629	16.04.99	PL	D-32339 Espelkamp					
Mod.	Dat.	Name						
							Sub. f. TB 09 20 003 1750 v.24.02.92	
							Blatt/page	