

REV.	DESCRIPTION	DRAWN	CHECKED	APPROVED
A	NEW RELEASE	LJH 04/27/05'		LJH 04/22/06'
B	ADD SCREW TYPE	DMJ 06/27/07'		LJC 06/27/07'
C	整理图画	YCH 05/21/08'		LJC 05/21/08'
D	整理图画	YCH 09/26/08'		

NOTES:

- ELECTRICAL CHARACTERISTICS:
 - CONTACT RESISTANCE: 20mΩ Max. INITIAL.
 - DIELECTRIC WITHSTANDING VOLTAGE: 500V AC(rms) FOR 1 MINUTE.
 - INSULATION RESISTANCE: 1000MΩ Min.
- ENVIRONMENT CHARACTERISTICS: TEMPERATURE RANGE: -45°C~+105°C.
- PART NUMBER: DS1034
- PRODUCT NUMBER CODE:

DS1034- X X X X X X X

SCREW DIM. A
 S: Standard(W/O nut)
 1: 5.00
 2: 3.00
 3: 5.20
 4: 4.80
 5: 5.80
 6: 4.00
 7: 4.80mm(Inside thread M2.6*0.45p, outside thread unc#4-40)

SCREW TYPE
 S: Standard(W/O nut)
 1: CC TYPE
 2: CS TYPE
 3: BR TYPE
 4: BRJ TYPE DIM. B:6.00 C: 3~4mm
 5: BRJ TYPE DIM. B:6.00 C: 5~6mm
 6: BRJ TYPE DIM. B:6.00 C: 3~4mm (Inside thread M2.6*0.45P,outside thread unc#4-40)

CONTACT PLATING
 Si: FULL GOLD FLASH
 0: SELECTIVE GOLD FLASH

SHELL PLATING
 T: FORNT & BACK SHELL TIN
 N: FORNT SHELL NICKEL,BACK SHELL TIN

HOUSING COLOR
 B: BLACK
 W: WHITE
 U: BLUE

CONNECTOR TYPE
 M: MALE
 F: FEMALE

No.OF CONTACTS
 09: 9pos. 25: 25pos.
 15: 15pos. 37: 37pos.

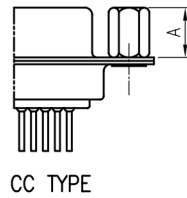
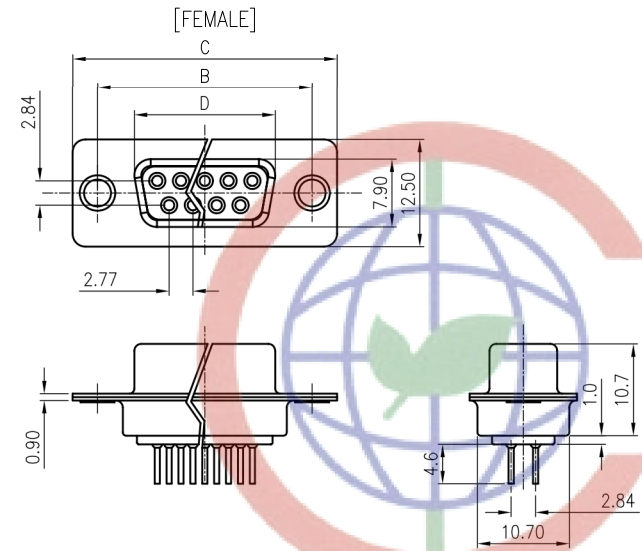

CC TYPE

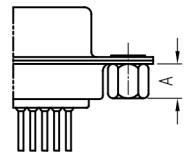

CS TYPE

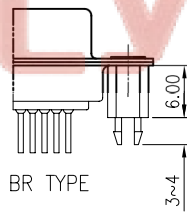

BR TYPE

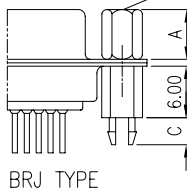

BRJ TYPE

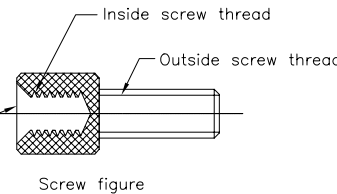

Screw figure

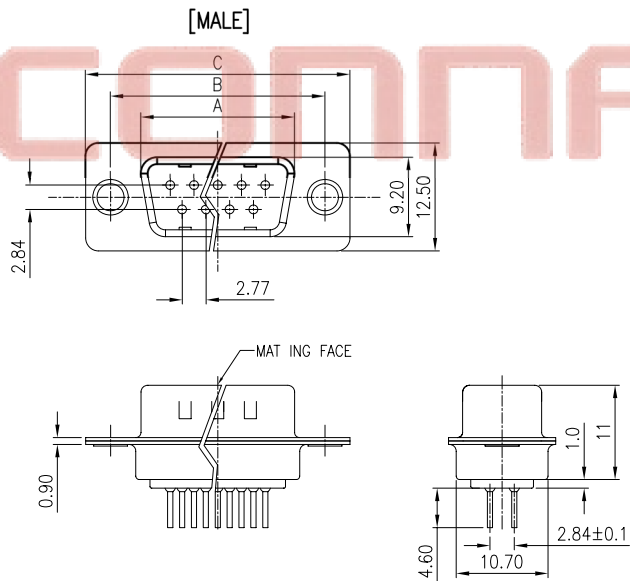

Dimension

Position	A±0.2	B±0.2	C±0.3	D
9	17.90	24.99	30.80	16.33
15	26.50	33.32	39.14	24.66
25	40.00	47.04	53.04	38.38
37	56.50	63.50	69.32	54.84

GENERAL TOLERANCE

X.	±0.60
.X	±0.38
.XX	±0.25

ANGLE TOLERANCE

X.	±5'
.X	±3'
.XX	±2'

PROJECTION



UNITS

mm

SHEET SIZE

A4

TITLE

D-SUB DIP STRAIGHT TYPE

SERIES

DS1034 SERIES

DRAWING TYPE

CUSTOMER

SCALE

1:1

SHEET

1 OF 1

DRAWING NO.

C-DS1034-XXXXXXX



晨翔电子有限公司

CONNFLY CONNFLY ELECTRONIC CO. LTD

Tel: 86-574-63508787

Fax: 86-574-63510817

Email: sales@connfly.com.cn

Http://www.connfly.com.cn

Address: West Xuhou Road, Cixi Ningbo China

Phone: 86-574-63515321