

SECTION B-B
SCALE 2 : 5

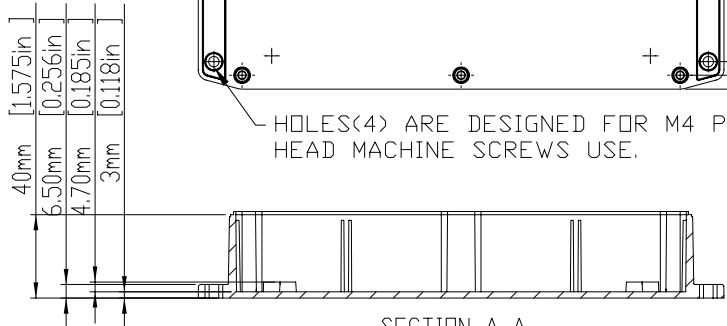

SECTION A-A
SCALE 2 : 5

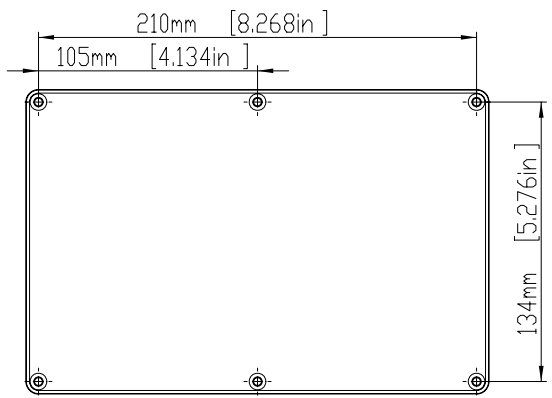
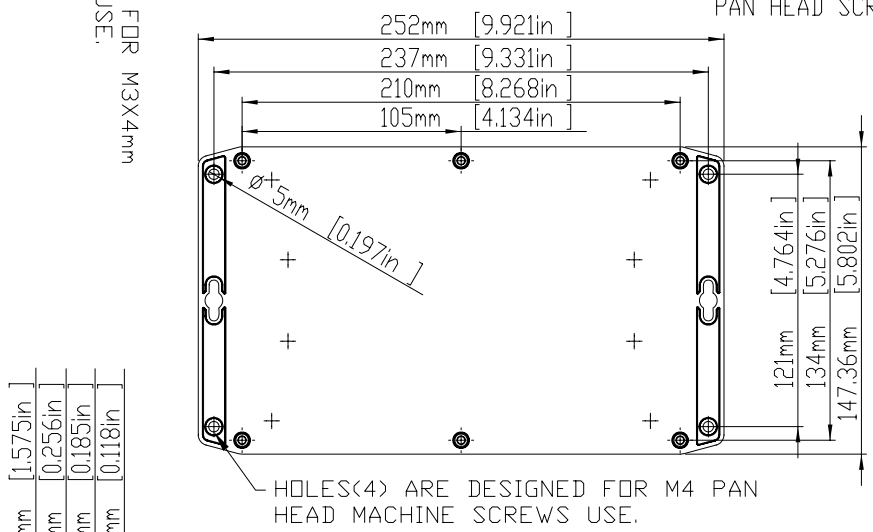
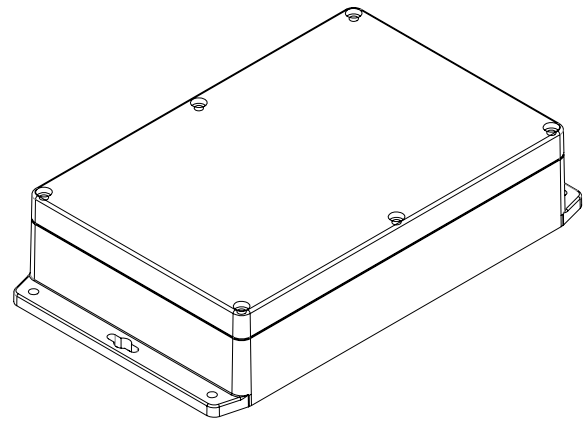
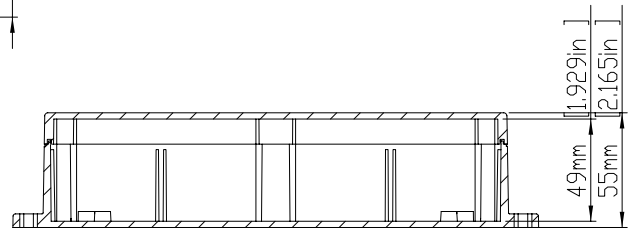

TOLERANCES: +/- 0.30 mm (+/- 0.012in)

宣又實業有限公司 GAINTA INDUSTRIES LTD.	繪圖	DRA'D BY	日期	DATE	材質	MATE.	圖名TITLE:	圖號DWG NO:	版次REVISID:
		JACKY	2010/11/8		PC ; ABS		G218MF ; G317MF		A

STOCK NO.	MATERIAL	BASE-COLOR	COVER-COLOR
G218MF	POLYCARBONATE UL94-HB	LIGHT GRAY(RAL7035)	LIGHT GRAY(RAL7035)
G218CMF	POLYCARBONATE UL94-HB	LIGHT GRAY(RAL7035)	CLEAR
G317MF	ABS UL94-HB	DARK GRAY(RAL7000)	DARK GRAY(RAL7000)

宣又實業有限公司
GAINTA INDUSTRIES LTD.

繪圖 DRA'D BY
JACKY

日期 DATE
2010/11/30

材質 MATE.
PC;ABS

圖名TITLE:
G218MF ; G317MF

圖號DWG NO:

版次REVISID:

A